

**JHS-207**

---

**TWO-WAY RADIOTELEPHONE APPARATUS/  
ON-BOARD COMMUNICATION EQUIPMENT**

**INSTRUCTION  
MANUAL**



# Preface

Thank you for purchasing JRC's JHS-207 two-way radiotelephone. This radiotelephone can be used as a hand-held portable VHF radiotelephone for on- scene, life-saving two-way communication between survival craft, between survival craft and ship, and between ship and rescue boat in accordance with SOLAS convention.

- Please read this instruction manual thoroughly before using the equipment.
- Please keep this manual available for future reference. Please refer to it if any difficulties are encountered when using the equipment.

# Before Operation

## Concerning the symbols

This manual uses the following symbols to explain correct operation and to prevent injury or damage to property.

The symbols and descriptions are as follows. Understand them before proceeding with this manual.



## **WARNING**

Indicates a warning that, if ignored, may result in serious injury or even death.



## **CAUTION**

Indicates a caution that, if ignored, may result in injury or damage to property.

## Examples of symbols



The  $\triangle$  symbol indicates caution (including DANGER and WARNING). The illustration inside the  $\triangle$  symbol specifies the content of the caution more accurately. (This example warns of possible electrical shock.)



The  $\otimes$  symbol indicates that performing an action is prohibited. The illustration inside the  $\otimes$  symbol specifies the contents of the prohibited operation. (In this example disassembly is prohibited.)



The  $\bullet$  symbol indicates operations that must be performed. The illustration inside the  $\bullet$  symbol specifies obligatory instructions. (In this example unplugging is the obligatory instruction.)

## Handling precaution

# **WARNING**



Do not use this JHS-207 in hazardous areas subject to the presence of explosive gases.



Do not open forcibly for the equipment to repair it. Inspection or repairs by anyone other than a specialized technician may result in fire, electrical shock, or malfunction.



If repair is necessary, contact our service center or agents.



Do not disassemble or customize this unit. Doing so may cause malfunction.



Do not use a voltage other than specified.  
Doing so may cause fire, electrical shock, or malfunction.



Do not short circuit, puncture, incinerate, crush, immerse, force discharge or expose to temperatures above the declared operating temperature range of the product, otherwise you risk fire or explosion.



A battery that is disassembled or exposed to water, fire or high temperatures can explode or leak causing burns.



Doing any of the following could result in sever burn hazard or fire explosion:

- Heating a lithium battery over 70 degrees celsius
- Attempting to recharge the battery.
- Crushing, disassembling or attempting to ignite or set flame to the battery.



If any problem is observed in this unit on usual operation or inspection, contact JRC or our agent. In addition to usual communication, this unit is also used for the distress communication.



# CAUTION



Do not use this equipment for anything other than specified. Doing so may cause failure or malfunction.



Do not touch contents of an open battery. It can cause skin irritation and respiratory irritation.



Changing the battery must be done in a dry environment or under shelter as the radio is only waterproof when the battery, antenna and jack cover are correctly assembled.



The JHS-207 unit is not waterproof when the standard antenna is not attached or if the antenna is not assembled correctly.



When using an accessory, the radio will no longer be waterproof. The antenna and jack cover must be correctly assembled on the radio in order for it to be completely waterproof. Accessories should not be used when using the JHS-207 in the emergency mode.



Place the radio in a location away from direct sea spray, chemicals, oil and vibration.



Accessories should not be used when using the JHS-207 in the emergency mode.



The JHS-207 is a sealed waterproof radio, and does not contain any user serviceable parts inside. This radio must never be opened by anyone other than an authorized JRC agent. Unauthorized disassembly will void your warranty.



# CAUTION



Do not use Channel 16 for the regular testing.



Improper maintenance may destroy the functionality and/or performance of this product.

# Emergency instructions

This is an overview of how to operate a JHS-207 during an emergency.

## JHS-207

**1**  
Take emergency battery out of the charger

**2**  
Remove safety seal

**3**  
Insert emergency battery

Take emergency battery out of the charger

Remove safety seal

Insert emergency battery

|   |          |
|---|----------|
| A | Alfa     |
| B | Bravo    |
| C | Charlie  |
| D | Delta    |
| E | Echo     |
| F | Foxtrot  |
| G | Golf     |
| H | Hotel    |
| I | India    |
| J | Juliett  |
| K | Kilo     |
| L | Lima     |
| M | Mike     |
| N | November |
| O | Oscar    |
| P | Papa     |
| Q | Quebec   |
| R | Romeo    |
| S | Sierra   |
| T | Tango    |
| U | Uniform  |
| V | Victor   |
| W | Whiskey  |
| X | X-ray    |
| Y | Yankey   |
| Z | Zulu     |

**F** Functions

On/off      Channel 16      Volume      Squelch      PTT

**P** Emergency procedure

Select channel 16  
Push To Talk (PTT):

"MAYDAY.. MAYDAY.. MAYDAY..."  
 "This is .. [own ships name].. [own ships name].. [own ships name]"  
 "Call sign: [own ships callsign]... MMSI: [own ships MMSI]"  
 "Over"

Continue emergency message with useful information for example:  
 Position, Nature of distress ,Nature of assistance required.

Own ship name: ..... Call sign: ..... MMSI: .....



# Table of contents

---

|       |   |    |
|-------|---|----|
| 1.    | List of figures.....                                  | 1  |
| 2.    | Abbreviations.....                                    | 2  |
| 3.    | General.....  | 5  |
| 4.    | Standards.....  | 7  |
| 5.    | Product description.....                              | 11 |
| 5.1   | Product image.....                                    | 12 |
| 5.2   | Basic configuration.....                              | 13 |
| 5.2.1 | Basic configuration of the main unit.....             | 13 |
| 5.2.2 | Option.....   | 13 |
| 5.3   | External dimensions.....                              | 14 |
| 6.    | Battery safety instructions (GMDSS radio).....        | 19 |
| 6.1   | Hazards identification.....                           | 20 |
| 6.2   | First aid measures.....                               | 21 |
| 6.3   | Fire fighting measures.....                           | 21 |
| 6.4   | Accidental release measures.....                      | 22 |
| 6.5   | Handling and storage.....                             | 23 |
| 6.5.1 | Transportation.....                                   | 23 |
| 7.    | Battery safety instructions (Maritime VHF radio)..... | 24 |
| 7.1   | Hazards identification.....                           | 25 |
| 7.2   | First aid measures.....                               | 26 |
| 7.3   | Fire fighting measures.....                           | 26 |
| 7.4   | Accidental release measures.....                      | 27 |

---

|       |   |    |
|-------|---|----|
| 7.5   | Handling and storage.....                   | 28 |
| 7.5.1 | Transportation.....                         | 28 |
| 8.    | Functional description.....                 | 29 |
| 8.1   | JHS-207 components.....                     | 29 |
| 8.2   | Antenna.....                                | 31 |
| 8.3   | Battery endurance.....                      | 31 |
| 8.4   | Emergency battery.....                      | 32 |
| 8.5   | Rechargeable battery.....                   | 33 |
| 8.6   | Battery charger (Including multi type)..... | 34 |
| 8.6.1 | Battery charger components.....             | 37 |
| 8.6.2 | Mounting the Battery charger.....           | 38 |
| 8.6.3 | LED indicator.....                          | 39 |
| 9.    | Technical specifications.....               | 41 |
| 9.1   | JHS-207 specification.....                  | 41 |
| 9.2   | Option specification.....                   | 43 |
| 9.2.1 | NBB-748 Rechargeable Battery.....           | 43 |
| 9.2.2 | NBB-789 Emergency Battery.....              | 43 |
| 9.2.3 | NJD101037 Battery Charger.....              | 43 |
| 9.2.4 | NJD101038 Power supply.....                 | 43 |
| 9.2.5 | 7ZXJD0185 Peripheral set.....               | 43 |
| 9.2.6 | NZB-191 Multi battery charger.....          | 44 |
| 9.2.7 | NJD19601 Headset push to talk module.....   | 44 |
| 9.2.8 | 7UMJD0021 Speaker Microphone.....           | 45 |
| 10.   | Installation.....                           | 45 |
| 10.1  | Upon receipt of the radio.....              | 45 |

---

|        |  |    |
|--------|--|----|
| 10.2   | In an emergency situation.....                   | 46 |
| 10.3   | Replacing the emergency battery.....             | 48 |
| 10.4   | Installing the rechargeable battery.....         | 48 |
| 10.5   | Changing the rechargeable battery.....           | 49 |
| 11.    | Operation instructions (GMDSS radio).....        | 51 |
| 11.1   | Emergency mode.....                              | 51 |
| 11.2   | Channel selection.....                           | 52 |
| 11.3   | Channel 16 button.....                           | 53 |
| 11.4   | Volume adjustment.....                           | 53 |
| 11.5   | Squelch adjustment.....                          | 54 |
| 11.6   | Key lock and unlock.....                         | 55 |
| 11.7   | Watch.....                                       | 55 |
| 11.7.1 | Dual watch.....                                  | 56 |
| 11.8   | Menus.....                                       | 57 |
| 12.    | Operation instructions (Maritime VHF radio)..... | 63 |
| 12.1   | Regular radio mode.....                          | 63 |
| 12.2   | Channel selection.....                           | 64 |
| 12.3   | Channel 16 button.....                           | 64 |
| 12.4   | Call channel.....                                | 65 |
| 12.5   | Custom channels.....                             | 66 |
| 12.6   | Volume adjustment.....                           | 67 |
| 12.7   | Squelch adjustment.....                          | 67 |
| 12.8   | Key lock and unlock.....                         | 69 |
| 12.9   | Watch.....                                       | 69 |
| 12.9.1 | Dual watch.....                                  | 70 |
| 12.9.2 | Triple watch.....                                | 71 |

---

|          |                          |    |
|----------|--------------------------|----|
| 12.9.3   | Scan                     | 72 |
| 12.9.3.1 | Scan Prog                | 73 |
| 12.10    | Menus                    | 74 |
| 12.11    | External accessories     | 81 |
| 13.      | Maintenance              | 83 |
| 13.1     | Regular inspection       | 83 |
| 13.2     | Regular testing          | 84 |
| 14.      | Channels and frequencies | 87 |
| 14.1     | GMDSS                    | 88 |
| 14.2     | International (ITU)      | 89 |
| 14.3     | USA                      | 90 |
| 14.4     | Canada                   | 91 |
| 15.      | After-sales service      | 93 |
| 16.      | Disposal                 | 95 |

# 1 List of figures

---

|   |    |
|---|----|
| Figure 1 JHS-207  | 12 |
| Figure 2 JHS-207 in the Battery charger                                     | 12 |
| Figure 3 JHS-207 components   | 29 |
| Figure 4 Battery charger - charging and storage bays                        | 35 |
| Figure 5 Radio in the charging bay and Emergency battery in the storage bay | 35 |
| Figure 6 Battery charger components   | 37 |

## 2 Abbreviations

|       |  |
|-------|--|
| ADR   | European Agreement concerning the International Carriage of Dangerous Goods by Road  |
| CFR   | The Code of Federal Regulations  |
| DW    | Dual Watch (Receiver altering between two different channels)  |
| ECHA  | European Chemical Agency   |
| EMC   | Electromagnetic compatibility  |
| ESD   | Electrostatic discharge  |
| ETS   | European Telecommunications Standard   |
| ETSI  | European Telecommunications Standards Institute  |
| GMDSS | Global Maritime Distress and Safety System   |
| HW    | Hardware   |
| IATA  | International Air Transport Association  |
| ICAO  | International Civil Aviation Organization  |
| IEC   | International Electrotechnical Commission  |
| IMDG  | International Maritime Dangerous Goods Code  |
| MHz   | MegaHertz  |
| MSDS  | Material Safety Data Sheet   |
| NC    | Noise cancel   |
| OSHA  | Occupational Safety and Health Admin   |
| PTT   | Push to talk   |
| RES   | Radio equipment and systems (technical committee of ETSI)  |
| RID   | Reglement concernant le transport International ferroviare des marchandises Dangereuses par chemin de fer (Transportation of Dangerous Goods by Train) |

|       |  |
|-------|--|
| RMA   | Return Material Authorization number                                 |
| RSS   | Radio Standards Specification  |
| SDS   | Safety Data Sheet  |
| SMA   | Sub miniature version A connector                                    |
| SOLAS | Safety of Life at Sea (An international maritime safety treaty)      |
| STCW  | Standards of training, certification and watch keeping for seafarers |
| SW    | Software   |
| TW    | Triple Watch   |
| UN    | United Nations   |
| VAC   | Volts, alternating current (AC)                                      |
| VHF   | Very High Frequency  |





# 3 General

JRC manufactures safety equipment designed for the search and rescue of human life and property. For safety equipment to be effective according to the design parameters it is imperative that all products are handled, maintained, serviced and stowed in compliance with the manufacturer's instructions.

All information contained within this manual has been verified and is to our knowledge correct, however, JRC reserves the right to make changes to any product(s) or module(s) described herein to improve reliability, function or design, without further notice.

## **Important**

JRC is not liable for consequential or special damages and cannot be held responsible for any damages or injury arising either directly or indirectly due to an error or omission of information, misuse of a product, breach of procedures, or for failure of any specific component or other part of the equipment



# 4 Standards

JHS-207 (GMDSS – emergency mode) has been verified, tested and meets the following product standards.

|  |  |
|--|--|
| EN/IEC 60945: 2002 including Corr.1<br>(Category - Portable) | Maritime navigation and radio communication equipment and systems - General requirements - Methods of testing and required test results  |
| ETSI EN 300225, V1.4.1 (2004-12)                             | Electromagnetic compatibility and Radio spectrum Matters (ERM); Technical characteristics and methods of measurement for survival craft portable VHF radiotelephone apparatus  |
| ETSI EN 301 843-1, V1.2.1 (2004-06)                          | Electromagnetic compatibility and Radio spectrum Matters (ERM); Electro Magnetic Compatibility (EMC) standard for marine radio equipment and services; Part 1: Common technical requirements   |
| ETSI EN 301 843-2, V1.2.1 (2004-06)                          | Electromagnetic compatibility and Radio spectrum Matters (ERM); Electro Magnetic Compatibility (EMC) standard for marine radio equipment and services; Part 2: Specific conditions for VHF radiotelephone transmitters and receivers |
| IEC 61097-12: 1996   | Global maritime distress and safety system (GMDSS) - Part 12: Survival craft portable two-way VHF radiotelephone apparatus - Operational and performance requirements, methods of testing and required test results                  |

RSS-102, Issue 5: Mar. 2015

Radio Frequency (RF) Exposure Compliance of Radio communication Apparatus (All Frequency Bands)

RSS-182, Issue 5: Jan. 2012

Maritime Radio Transmitters and Receivers in the Band 156-162.5 MHz

JHS-207 (Maritime VHF – regular mode) has been verified, tested and meets the following product standards:

EN 62479: 2010

Assessment of the compliance of low power electronic and electrical equipment with the basic restrictions related to human exposure to electromagnetic fields (10 MHz to 300 GHz)

ETSI EN 301 178, V2.2.2 (2017-04)

ETSI EN 301 178 V2.2.2 (2017-04) Portable Very High Frequency (VHF) radiotelephone equipment for the maritime mobile service operating in the VHF bands (for non-GMDSS applications only); Harmonised Standard covering the essential requirements of article 3.2 of Directive 2014/53/EU

ETSI EN 301 178-1, V1.3.1: 2007-02

Electromagnetic compatibility and Radio spectrum Matters (ERM); Portable Very High Frequency (VHF) radiotelephone equipment for the maritime mobile service operating in the VHF bands (for non-GMDSS applications only); Part 1: Technical characteristics and methods of measurement

ETSI EN 301 178-2, V1.2.2: 2007-02

Electromagnetic compatibility and Radio spectrum Matters (ERM); Portable Very High Frequency (VHF) radiotelephone equipment for the maritime mobile

|                                     |  |
|-------------------------------------|--|
|                                     | operating in the VHF bands (for non-GMDSS applications only); Part 2: Harmonized EN covering essential requirements of article 3.2 of the R & TTE Directive  |
| ETSI EN 301 843-1, V1.2.1 (2012-08) | Electromagnetic compatibility and Radio spectrum Matters (ERM); Electro Magnetic Compatibility (EMC) standard for marine radio equipment and services; Part 1: Common technical requirements   |
| ETSI EN 301 843-2, V1.2.1 (2004-06) | Electromagnetic compatibility and Radio spectrum Matters (ERM); Electro Magnetic Compatibility (EMC) standard for marine radio equipment and services; Part 2: Specific conditions for VHF radiotelephone transmitters and receivers   |
| IEC 62209-1:2005                    | Human exposure to radio frequency fields from hand- held and body-mounted wireless communication devices - Human models, instrumentation, and procedures - Part 1: Procedure to determine the specific absorption rate (SAR) for hand-held devices used in close proximity to the ear (frequency range of 300 MHz to 3 GHz)                    |
| IEC 62209-2: 2010                   | Human exposure to radio frequency fields from hand- held and body-mounted wireless communication devices - Human models, instrumentation, and procedures - Part 2: Procedure to determine the specific absorption rate (SAR) for wireless communication devices used in close proximity to the human body (frequency range of 30 MHz to 6 GHz) |
| IEC 62368-1:2014                    | Audio/video, information and communication technology equipment - Part 1: Safety requirements  |

**Important**

The use of JHS-207 with the rechargeable LiPo battery may be subject to an operator certificate in accordance with RED 2014/53/EU, Article 10.10.

Prior to using this equipment, please check with your local national radio license authority.

47 CFR 2.1093: Oct. 2013

Radio frequency radiation exposure evaluation: portable devices.

47 CFR 80 to End: Oct. 2015

Electronic Code of Federal Regulations, Title 47, Telecommunications

**Important**

This device complies with the GMDSS provision of part 80 of the FCC Rules. Any changes or modifications not expressly approved by the party responsible for compliance could void the user's authority to operate this equipment.



The relevant CE marking of CE0168! is found on the product and the packaging.

# 5 Product description

The JHS-207 is a ruggedly designed radio made for easy operation. It is a portable survival craft two-way VHF radio which is possible to operate using one hand, even when wearing gloves. The high contrast graphical display including integrated back lighting of the display and keys are very effective for visibility and usage in low light conditions.

It is also resistant to oil, seawater and sunlight. This radio is compact in size with smooth edges to avoid damage to clothing or a raft. The highly visible orange housing is made from glass reinforced polycarbonate.

The JHS-207 GMDSS (emergency mode) radio is waterproof down to 1 meter and floats in freshwater, battery included. The radio is designed with a self draining loudspeaker. The JHS-207 is only completely waterproof when the antenna and jack cover are assembled on the radio correctly.

## 5.1 Product image



Figure 1 JHS-207



Figure 2 JHS-207 in the Battery charger



## 5.2 Basic configuration

### 5.2.1 Basic configuration of the main unit

JHS-207M package (GMDSS & Maritime VHF radio)

| No. | Product Name  | Model Name | QTY |
|-----|---|------------|-----|
| 1   | Two-way VHF Radiotelephone                          | JHS-207    | 1   |
| 2   | Antenna   | -          | 1   |
| 3   | Belt clip   | -          | 1   |
| 4   | Wrist strap   | -          | 1   |
| 5   | Emergency battery<br>(Primary Lithium iron battery) | NBB-789    | 1   |
| 6   | Rechargeable battery<br>(Secondary LiPo battery)    | NBB-748    | 1   |
| 7   | Battery charger                                     | NJD101037  | 1   |
| 8   | Power supply  | NJD101038  | 1   |

### 5.2.2 OPTION

#### Spare Parts

| No. | Product Name         | Parts number | Notes                                    |
|-----|----------------------|--------------|--|
| 1   | Emergency battery    | NBB-789      | Primary lithium iron battery             |
| 2   | Rechargeable battery | NBB-748      | Secondary lithium polymer (LiPo) battery |
| 3   | Battery charger      | NJD101037    |  |
| 4   | Power supply         | NJD101038    | For NJD101037                            |
| 5   | Antenna kit          | 7ABJD0009    | Antenna, jack plug cover, gasket         |
| 6   | Peripheral set       | 7ZXJD0185    | Belt-clip, wrist-strap                   |

#### Accessories

| No. | Product Name                | Parts number | Notes                                      |
|-----|-----------------------------|--------------|--|
| 1   | Speaker microphone          | 7UMJD0021    |  |
| 2   | Carry case                  | 7ZZJD0128    |  |
| 3   | Headset                     | NJD103000    | For NJD19601                               |
| 4   | PTT module                  | NJD19601     |  |
| 5   | Multi battery charger (kit) | NZB-191      | Wall or table mount type, up to 3 chargers |

## 5.3 External dimensions

### 1) Two-way Radiotelephone (JHS-207)

---

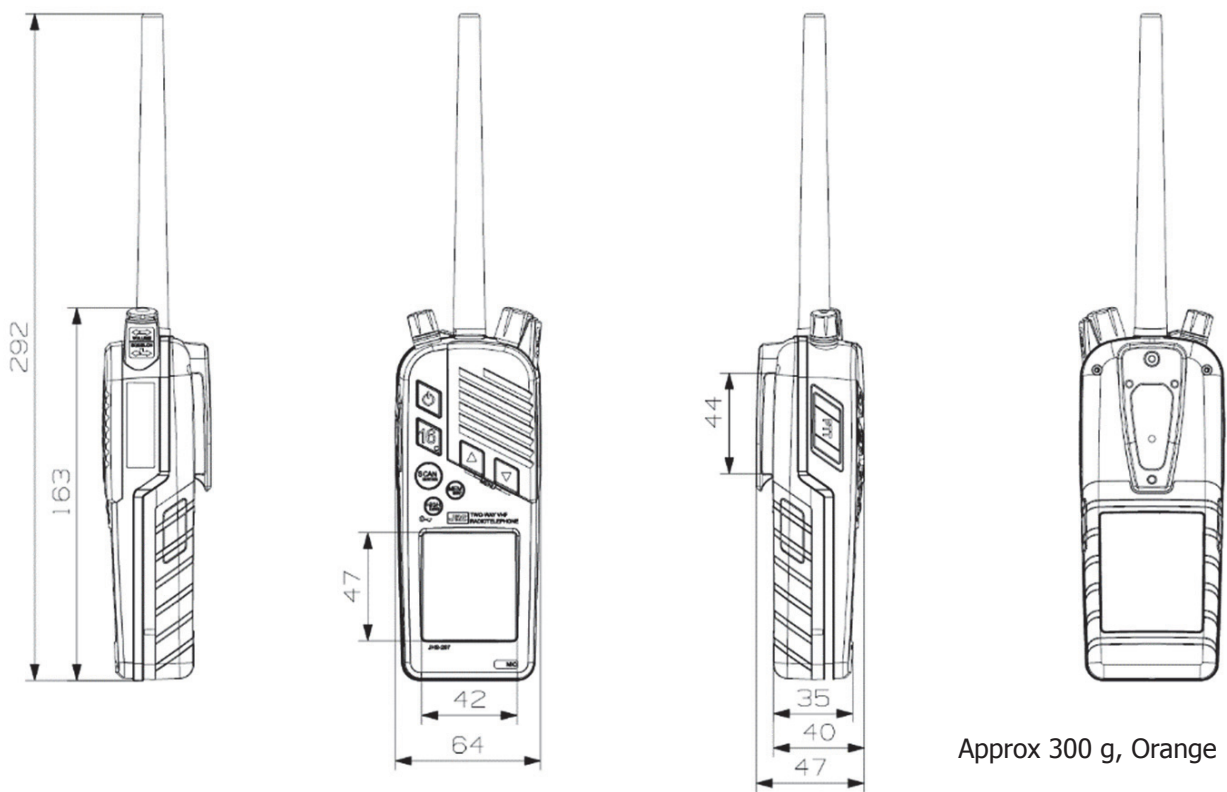

### 2) Battery (NBB-789 / NBB-748)

---

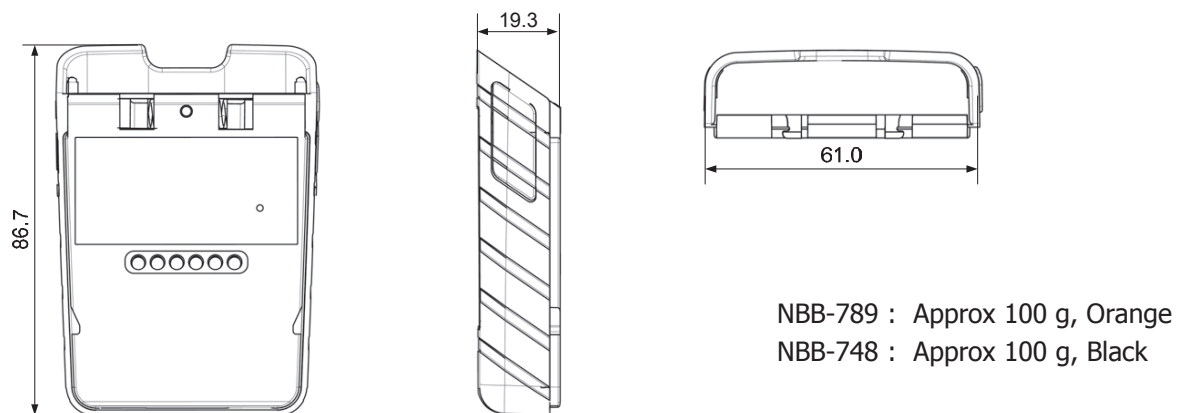

5) Battery charger (NJD101037)

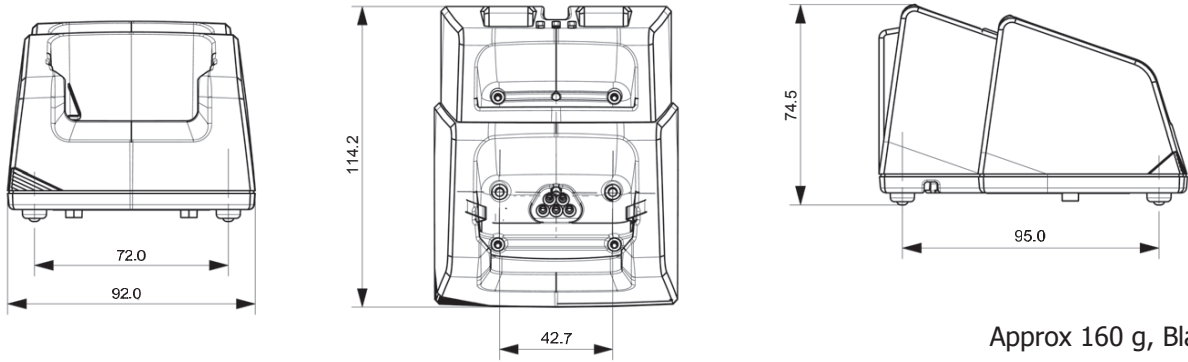

Approx 160 g, Black

6) Power supply (NJD101038)

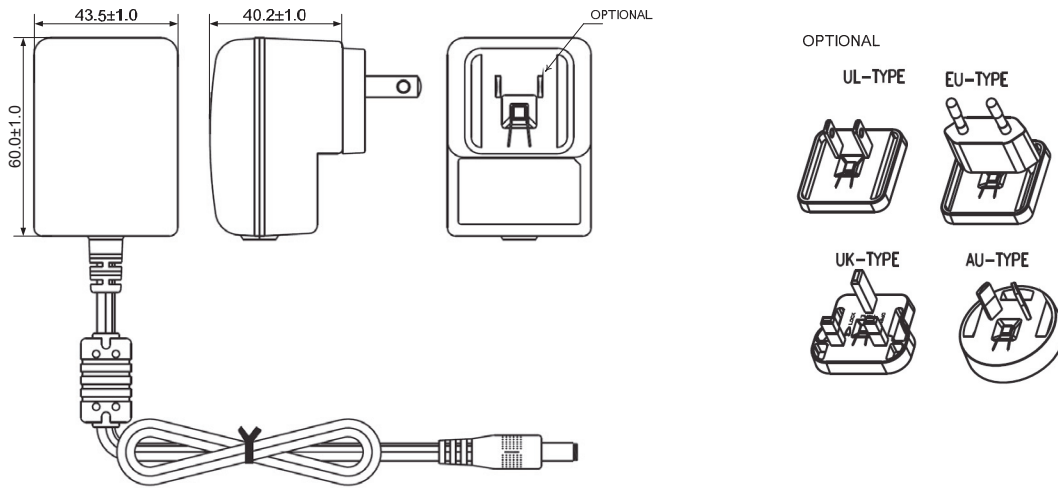

Approx 165 g, Black

7) Antenna kit (7ABJD0009)

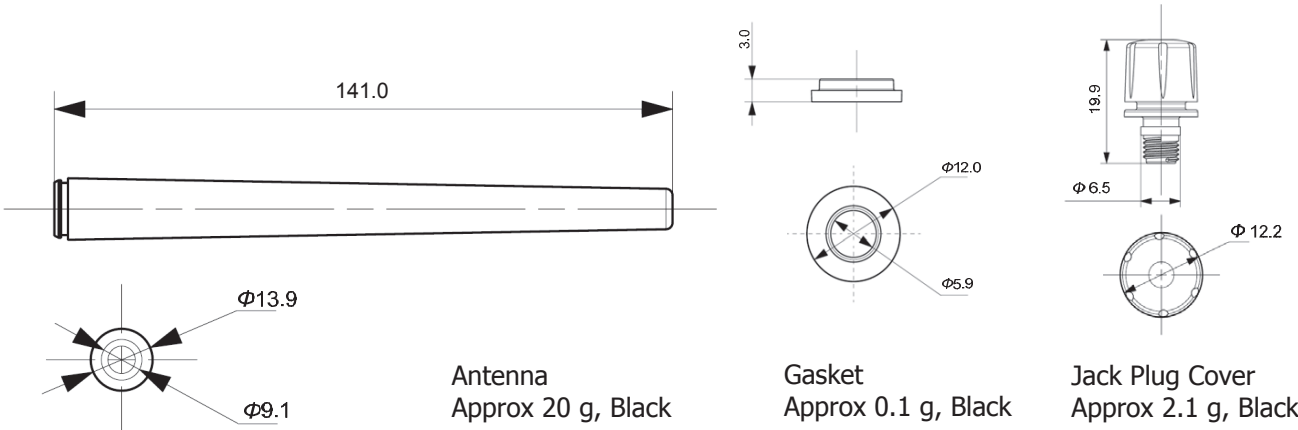

Antenna  
Approx 20 g, Black

Gasket  
Approx 0.1 g, Black

Jack Plug Cover  
Approx 2.1 g, Black

8) Peripheral set (7ZXJD0185)

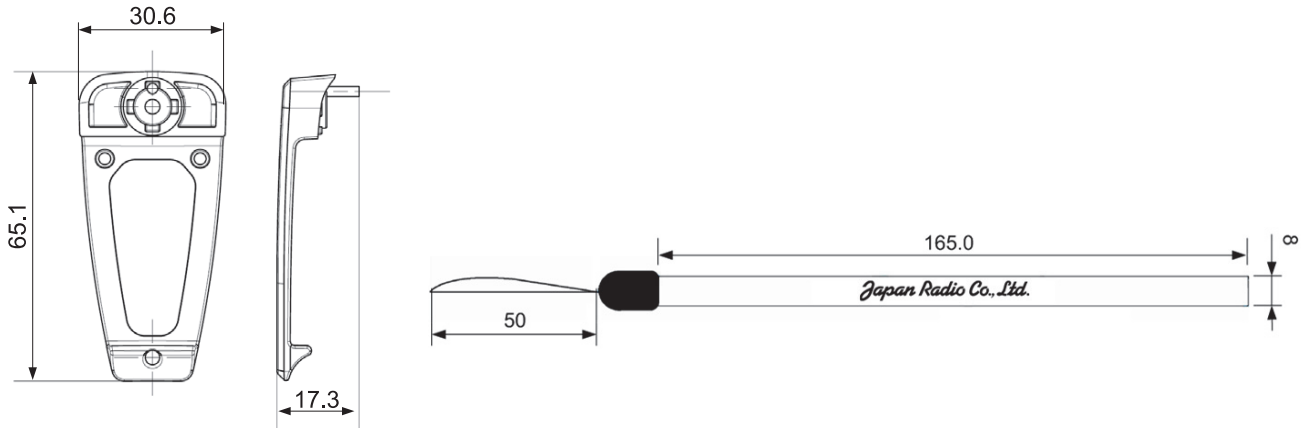

Belt clip  
Approx 5.5 g, Black

Wrist strap  
Approx 3.8 g, Black

9) Speaker microphone (7UMJD0021)

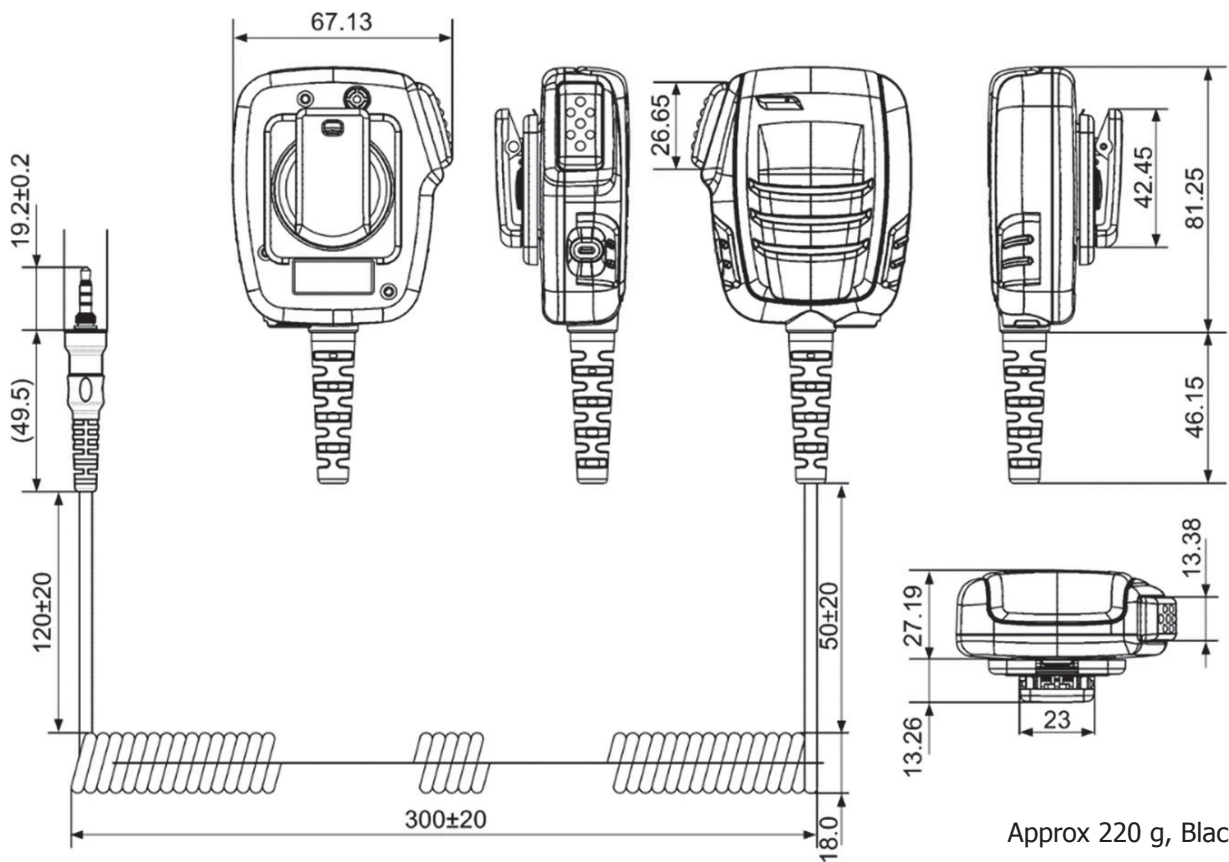

Approx 220 g, Black

10) Carry case (7ZZJD0128)

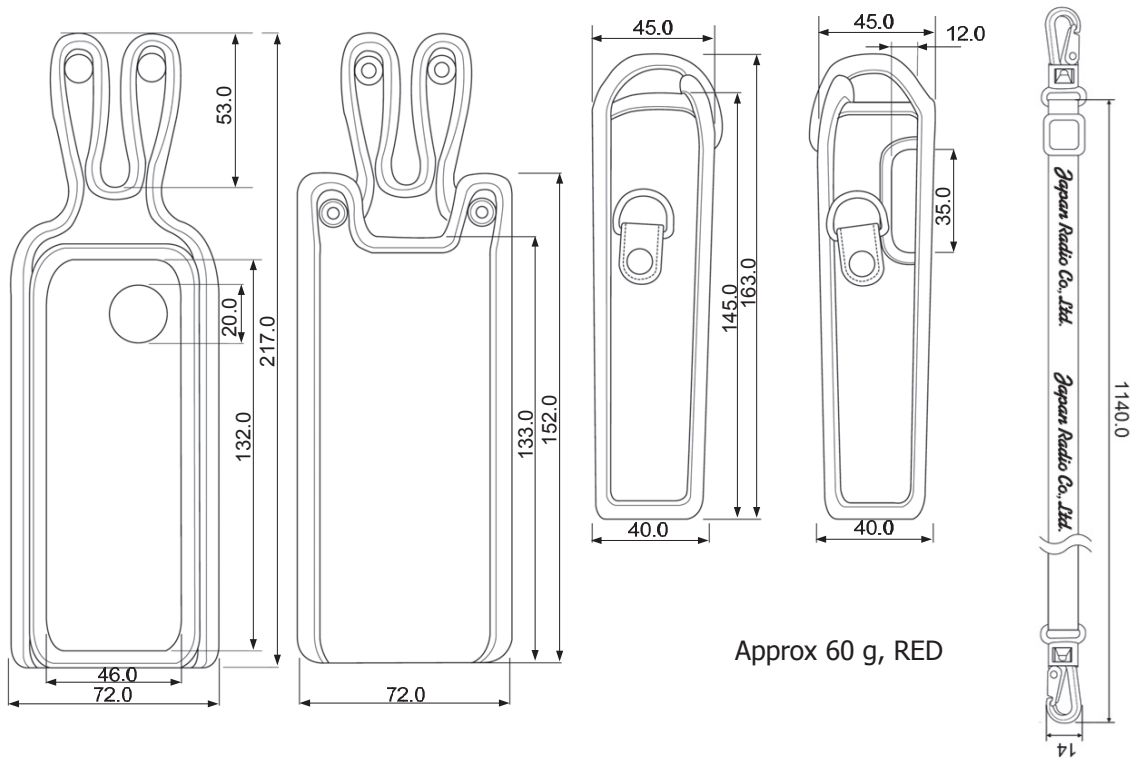

11) PTT module (NJD19601)

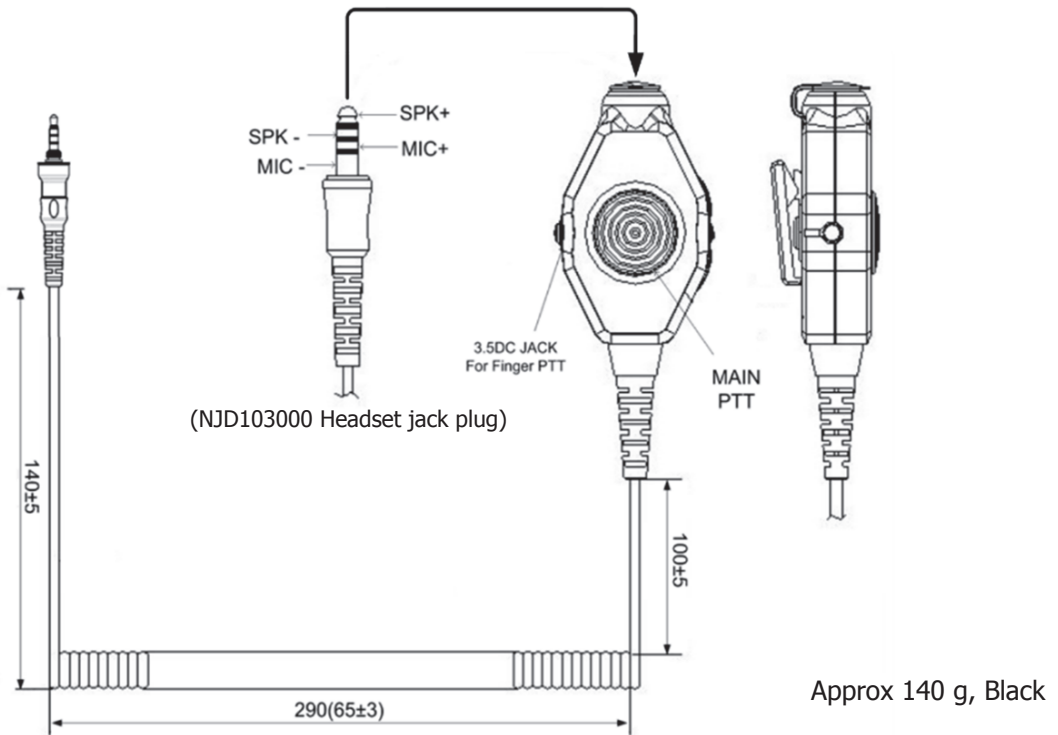

12) Multi battery charger (NZB-191) \*Wall or Desktop type

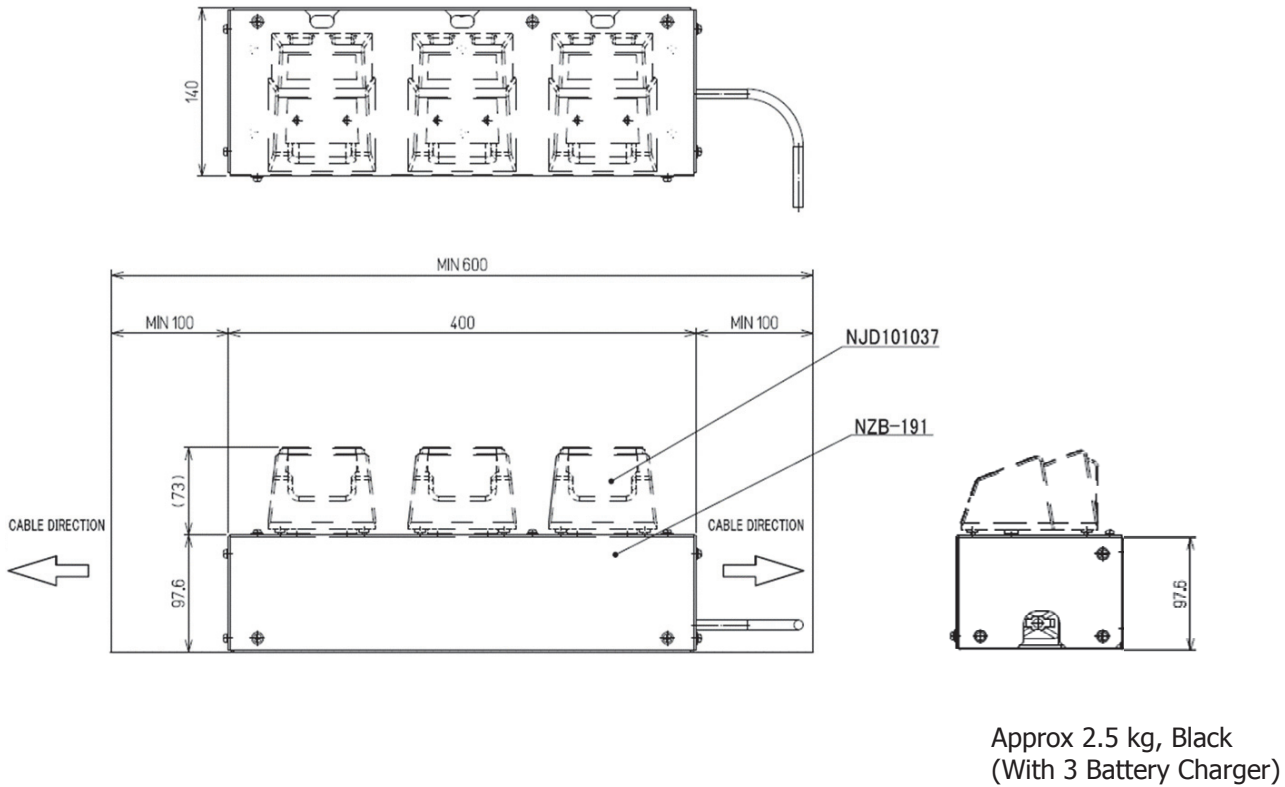

**Important**

The NZB-191 does not include battery chargers (NJD101037). When installing this kit, use the battery chargers bundled in the JHS-207 packages.

# 6 Battery safety instructions (GMDSS radio)

Under EC, European Chemical Agency (ECHA) and US, Occupational Safety and Health Admin (OSHA) legislation this product is classified as a manufactured article, which does not release or otherwise result in exposure to a hazardous chemical under the normal conditions of use.

Therefore, this product is exempt from the requirement of a dedicated Material Safety Data Sheet (MSDS) or Safety Data Sheet (SDS).

The following information is included in this manual as guided safety

|                             |                                  |
|-----------------------------|----------------------------------|
| instructions. Product name: | Emergency battery                |
| Type no.:                   | FR6                              |
| Lithium metal content:      | 2 x 1.96 gram lithium pr battery |
| Approximate weight:         | 100 grams                        |
| Chemical system:            | Lithium Iron Disulfide           |
| Designed for recharge:      | No                               |

Below are instructions for keeping the radio log and the radio operator's obligation according to national and international regulation:

1. The radio log shall be kept in accordance with requirements in the Radio Regulation, SOLAS Convention, national regulations regarding radio installations and the STCW Convention (STCW 95 including the STCW Code) including relevant regulation regarding watch keeping on board passenger and cargo ships.

2. Unauthorized transmissions and incidents harmful interference should, if possible, be identified, recorded in the radio log and brought to the attention of the Administration in compliance with the Radio Regulations, together with an appropriate extract from the radio log (STCW Code BVIII/2 No. 32).



Testing of radio equipment and reserve source of energy should occur:

|  |  |
|--|--|
| <br><b>NOTE</b> | The below safety information is extracted from EVE Energy SDS (sections 4, 5 and 6). |
|--|--|

## 6.1 Hazards identification

The lithium iron disulfide batteries used in the JHS-207 and described herein are sealed units.

Under normal conditions, the battery is hermetically sealed. These batteries are not hazardous when used as intended and recommended.

|  |  |
|--|--|
|  <b>WARNING</b> |  |
|                 | Do not short circuit, puncture, incinerate, crush, immerse, force discharge or expose to temperatures above the declared operating temperature range of the product, otherwise you risk fire or explosion. |





## CAUTION



Do not touch contents of an open battery. It can cause skin irritation and respiratory irritation.

## 6.2 First aid measures

|               |  |
|---------------|--|
| Inhalation:   | Provide fresh air and seek medical attention.  |
| Skin contact: | Remove contaminated clothing and shoes and wash skin with soap and water. Wash clothing and shoes prior to reuse. If irritation occurs, seek medical attention.        |
| Eye contact:  | Immediately flush eyes thoroughly with water for at least 15 minutes, lifting upper and lower lids, until no evidence of the chemical remains. Seek medical attention. |

## 6.3 Fire fighting measures

In case of fire where lithium batteries are present, flood area with water or smother with a Class D fire extinguisher appropriate for lithium metal, such as Lith-X.

Water may not extinguish burning batteries but will cool the adjacent batteries and control spreading fire. Burning batteries will burn themselves out.

Virtually all fires involving lithium batteries can be controlled by flooding with water, however, the contents of the battery will react with water and form hydrogen gas. In a confined space, hydrogen gas can form an explosive mixture. In this situation, a smothering agent is recommended. A smothering agent will extinguish burning lithium batteries.

### **Important**

Any person responding to such an emergency should wear a self-contained breathing apparatus.

Burning lithium iron disulfide batteries produces toxic and corrosive lithium hydroxide fumes and sulfur dioxide gas.

## 6.4 Accidental release measures

To clean up a leaking battery:

Ventilation requirements:

Room ventilation may be in areas where there are open or leaking batteries.

Respiratory protection:

Avoid exposure to electrolyte fumes from an open or leaking battery.

Eye protection:

Wear safety glasses with side shields if handling an open or leaking battery.

Gloves:

Use neoprene or natural rubber gloves when handling an open or leaking battery. Battery materials should be disposed of in a leak-proof container.

## 6.5 Handling and storage

The JHS-207 should be stored in a cool and well ventilated area. Elevated temperatures can result in a reduction of battery life. In locations that handle large quantities of lithium batteries, such as a warehouse, lithium batteries should be isolated from unnecessary combustibles.



### **WARNING**



A battery that is disassembled or exposed to water, fire or high temperatures can explode or leak causing burns.

### 6.5.1 Transportation



#### **NOTE**

About detailed documentation regarding transportation regulations for batteries in accordance with ICAO/IATA, IMDG code and/or ADR/RID, contact our service center or agent

# 7 Battery safety instructions (Maritime VHF radio)

Under EC, European Chemical Agency (ECHA) and US, Occupational Safety and Health Admin (OSHA) legislation this product is classified as a manufactured article, which does not release or otherwise result in exposure to a hazardous chemical under the normal conditions of use.

Therefore, this product is exempt from the requirement of a dedicated Material Safety Data Sheet (MSDS) or Safety Data Sheet (SDS).

The following information is included in this manual as guided safety instructions.

|                        |  |
|------------------------|--|
| Product name:          | Rechargeable battery (LiPo 1550 mAh)   |
| Type no.:              | GEP653759  |
|                        | Lithium metal content: 0.9 gram lithium pr<br>battery and 11.5 watt-hour rating (Wh) |
| Approximate weight:    | 100 grams  |
| Chemical system:       | Lithium Polymer  |
| Designed for recharge: | Yes  |

Below are instructions for keeping the radio log and the radio operator's obligation according to national and international regulation:

1. The radio log shall be kept in accordance with requirements in the Radio Regulation, SOLAS Convention, national regulations regarding radio installations and the STCW Convention (STCW 95 including the STCW Code) including relevant regulation regarding watch keeping on board passenger and cargo ships.

2. Unauthorized transmissions and incidents harmful interference should, if possible, be identified, recorded in the radio log and brought to the attention of the Administration in compliance with the Radio Regulations, together with an appropriate extract from the radio log (STCW Code BVIII/2 No. 32).

Testing of radio equipment and reserve source of energy should occur:



Monthly: Handheld VHF transceivers are to be tested using a test or rechargeable battery.

|   |   |
|---|---|
|  <p><b>NOTE</b></p> | <p>The below safety information is extracted from Green Energy Battery and MSDS info from Pony Test Lab's report (sections 4, 5 &amp; 6).</p> |
|---|---|

## 7.1 Hazards identification

The lithium polymer batteries used in the JHS-207 and described herein are sealed units.

Under normal conditions, the battery is hermetically sealed. These batteries are not hazardous when used as intended and recommended.

|  |   |
|--|---|
|  <b>WARNING</b> |   |
|                 | <p>Do not short circuit, puncture, incinerate, crush, immerse, force discharge or expose to temperatures above the declared operating temperature range of the product, otherwise you risk fire or explosion.</p> |



## **CAUTION**



Do not touch contents of an open battery. It can cause skin irritation and respiratory irritation.

## 7.2 First aid measures

Inhalation:

Provide fresh air and seek medical attention.

Skin contact:

Remove contaminated clothing and shoes and wash skin with soap and water. Wash clothing and shoes prior to reuse. If irritation occurs, seek medical attention.

Eye contact:

Immediately flush eyes thoroughly with water for at least 15 minutes, lifting upper and lower lids, until no evidence of the chemical remains. Seek medical attention.

## 7.3 Fire fighting measures

In case of fire where lithium batteries are present, use an extinguishing agent suitable for the location and surrounding environment, such as CO<sub>2</sub>.

A battery may burst and release hazardous decomposition products when exposed to fire. Lithium polymer batteries contain flammable electrolyte that may vent, ignite and produce sparks when subjected to high temperatures (>150°C/302°F), when damaged or abused (e.g. mechanical damage or electrical overcharging), may burn rapidly with flare-burning effect; may ignite other batteries in close proximity.

**Important**

Any person responding to such an emergency should wear a self-contained breathing apparatus.

Burning lithium polymer batteries produces toxic and corrosive lithium hydroxide fumes and sulfur dioxide gas.

## 7.4 Accidental release measures

|  |  |
|--|--|
| Personal precautions:                                  | Wear the proper personal protective equipment. Keep unprotected individuals away. Ensure adequate ventilation.   |
| Emergency procedures:                                  | Remove ignition sources, evacuate the area. Sweep up using a method that does not generate dust. Collect as much of the spilled material as possible, place the spilled material into an appropriate disposal container. Keep spilled material out of sewers, ditches and bodies of water. |
| Environmental precautions:                             | Do not allow material to be released into the environment without proper governmental permits.   |
| Methods and materials for containment and cleaning up: | All waste must refer to the United Nations, the national and local regulations for disposal.   |

## 7.5 Handling and storage

The JHS-207 should be stored in a cool and well ventilated area. Elevated temperatures can result in a reduction of battery life. In locations that handle large quantities of lithium batteries, such as a warehouse, lithium batteries should be isolated from unnecessary combustibles.



### **WARNING**



A battery that is disassembled or is exposed to water, fire or high temperatures can explode or leak causing burns.

### 7.5.1 Transportation



**NOTE**

About detailed documentation regarding transportation regulations for batteries in accordance with ICAO/IATA, IMDG code and/or ADR/RID, contact our service center or agent.



# 8 Functional description

## 8.1 JHS-207 components

An overview of the radio components.



Figure 3 JHS-207 components

- 1 Antenna
- 2 Volume, squelch and monitor control
- 3 Loudspeaker
- 4 Up arrow button
- 5 Down arrow button
- 6 Mem set (memory button)
- 7 Emergency mode indicator
- 8 Channel designator
- 9 Microphone
- 10 Squelch and signal strength indicator
- 11 Hi/medium/low (transmitter power indicator)
- 12 Battery charge indicator
- 13 Volume control indicator
- 14 Transmitter power adjustment (High/ Low button)
- 15 Scan/Enter button
- 16 Channel 16/Call channel button (instant access)
- 17 PTT Transmit button
- 18 On/off button
- 19 Jack cover (external accessories connector)

## 8.2 Antenna

The antenna for the JHS-207 is fitted with a standard SMA connector. You can also connect a remote antenna for a fixed application.



### CAUTION



The JHS-207 unit is not waterproof when the standard antenna is not attached or if the antenna is not assembled correctly.

## 8.3 Battery endurance

Below is a list of the operation times of the battery and usage.



NOTE

Use medium or low power when possible in order to maximize the operational time of the battery.

| Battery type         | Hours of usage* |                |
|----------------------|-----------------|----------------|
|                      | Standby time    | Multi-usage ** |
| Emergency battery    | 70              | 12             |
| Rechargeable battery | 50              | 12             |

|  |  |
|--|--|
|  <p><b>NOTE</b></p> | <p>* The hours indicated are based on 2W (tested at -20 degrees celsius).</p> <p>** Emergency battery multi-usage hours have been tested in accordance with 10:10:80 ratio (Send: Listen: Standby).</p> <p>** Rechargeable battery multi-usage hours have been tested in accordance with 5:5:90 ratio (Send: Listen: Standby).</p> <p>For more information refer to the ETS 300225 standard.</p> |
|--|--|

## 8.4 Emergency battery

The emergency battery (orange) is a lithium battery. This battery is specially designed for GMDSS emergency use and cannot be recharged. Keep the emergency battery in the battery storage bay, then it is easily accessible in a distress situation.

### **Important**

The emergency battery is a single use item. You must replace the battery before the battery expiry date and/or if the protective seal on the battery is broken.

|  |   |
|--|---|
|  <p><b>NOTE</b></p> | <p>Always bring a sealed emergency battery with the radio when boarding a lifeboat or raft.</p> |
|--|---|



## WARNING



Doing any of the following could result in severe burn hazard or fire explosion:

- Heating a lithium battery over 70 degrees celsius
- Attempting to recharge the battery.
- Crushing, disassembling or attempting to ignite or set flame to the battery.

## 8.5 Rechargeable battery

When using the rechargeable battery, additional functionality intended for regular radio usage is enabled. This battery can be recharged either while mounted to the radio or while standing alone in the Battery charger. The battery capacity is 7.4V/1550mAh.



NOTE

Ensure you check the battery for damage prior to use.

### **Important**

- This battery must be charged prior to use.
- Always use the dedicated Battery charger to recharge this battery.
- Charge a discharged battery within 1 week as the life of a battery diminishes greatly when stored in a discharged state.

## 8.6 Battery charger (Including multi type)

The Battery charger can charge either a single rechargeable battery or a JHS-207 with a rechargeable battery. In addition, this charger also has one extra battery storage bay for storing an emergency battery.

The charger will not charge a battery if the battery temperature is below 0 degrees celsius or above 40 degrees celsius, however, charging will automatically occur when the temperature is within the correct range.

### **Important**

The recommended charging temperature range is between 15-25 degrees celsius.

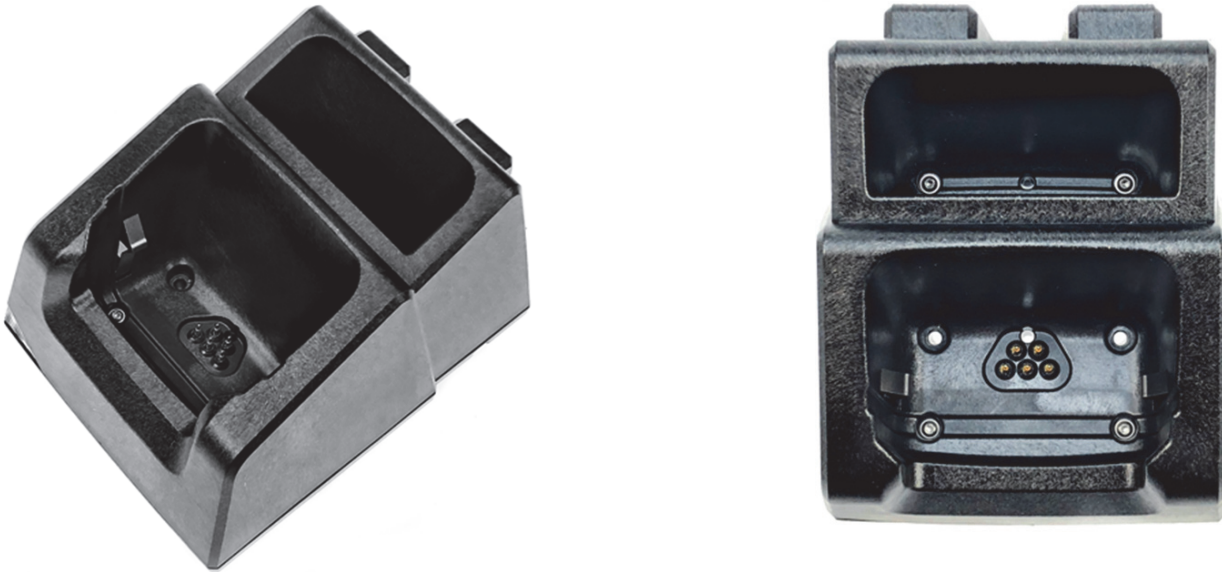

Figure 4 Battery charger - charging and storage bays



Figure 5 Radio in the charging bay and emergency battery in the storage bay

## **Important**

The battery charger is not waterproof and must therefore be protected from elements.



**NOTE**

Leaving the radio switched on during charging will increase the charging time.



## 8.6.1 Battery charger components

An overview of the Battery charger components.

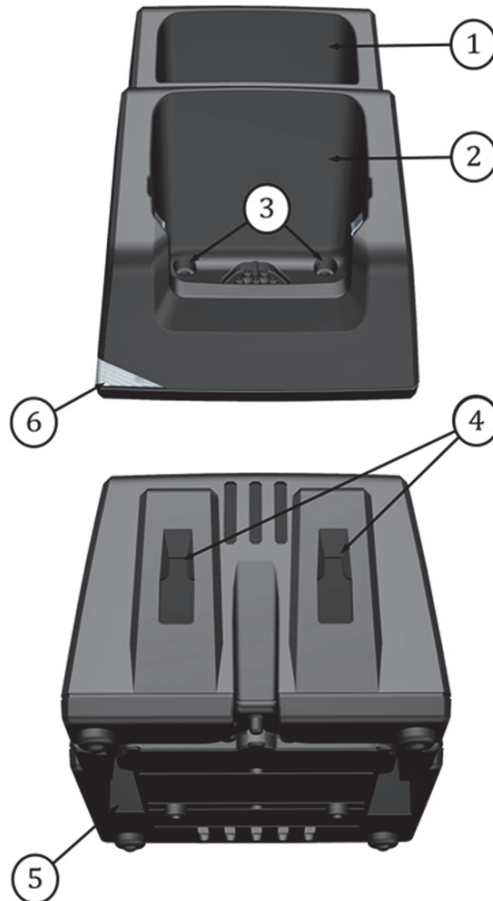

Figure 6 Battery charger components

- 1 Battery storage bay
- 2 Battery charger bay
- 3 Table mounting holes (42.7mm spacing)
- 4 Wall mounting holes (36.0mm spacing)
- 5 Power input
- 6 LED indicator

## 8.6.2 Mounting the Battery charger

The Battery charger can be securely mounted on a flat surface in one of two ways:

- Table mounting
- Wall mounting

To mount the JHS-207 (GMDSS radio), do the following:

1. Using either the two table mounting holes or the wall mounting holes, screw the Battery charger to the desired surface.



### **CAUTION**



Place the radio in a location away from direct sea spray, chemicals, oil and vibration.





**NOTE**

The JHS-207 must be easily accessible at all times for testing and maintenance.

### 8.6.3 LED indicator

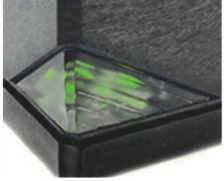
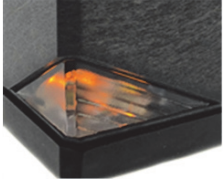
The LED indicator on the Battery charger displays the current battery status.

| Indicator color: | Status:                        | Color:   |
|------------------|--------------------------------|--|
| Green*           | The battery is fully charged   |   |
| Yellow           | The battery is charging        |   |
| Red              | There is a fault with charging |  |

\*A green light combined with a yellow blinking light also indicates the battery is fully charged.



# 9 Technical specifications

## 9.1 JHS-207 specification

| Overall:                    | Emergency mode<br>(emergency battery)             | Regular mode<br>(rechargeable battery)           |
|-----------------------------|---|--|
| Operating temperature range | -20 to +55  | -20 to +55                                       |
| Size (W/H/D)                | 61mm x 157mm x 40mm<br>(Dept with belt clip 47mm) | 61mm x 157mm x 40m<br>(Dept with belt clip 47mm) |
| Weight                      | Approximately 300 g                               | Approximately 295 g                              |
| Ingress protection rating   | IP67  | IP67   |
| Full buoyancy               | Yes   | Yes  |

| Receiver:                  | Emergency mode<br>(emergency battery) | Regular mode<br>(rechargeable battery) |
|----------------------------|---------------------------------------|--|
| Frequency range            | 154-157.425 MHz                       | 154-162 MHz                            |
| Channel spacing            | 25 kHz                                | 25 kHz                                 |
| Maximum usable sensitivity | < 1 $\mu$ V for 20dB<br>SINAD         | < 1 $\mu$ V for 20dB SINAD             |
| Adjacent channel rejection | > 70dB                                | > 70dB                                 |
| Blocking                   | > 90dB                                | > 90dB                                 |
| Spurious response          | > 70dB                                | > 70dB                                 |
| Harmonic distortion*       | < 5%                                  | < 5%                                   |
| Inter-modulation rejection | > 68dB                                | > 68dB                                 |
| Channel monitoring         | DW                                    | DW/TW/Scan                             |

| Transmitter:  | Emergency mode<br>(emergency battery) | Regular mode<br>(rechargeable battery)     |
|---|---------------------------------------|--|
| Frequency range                                     | 154-157.425MHz                        | 154-161.875MHz                             |
| Channel spacing                                     | 25 kHz                                | 25 kHz                                     |
| Transmitter output power<br>(fully charged battery) | Low: 1W, High: 2W                     | Low: 1W, Medium: 2W (default),<br>High: 4W |
| Harmonics and spurious                              | < 0.25 $\mu$ W                        | < 0.25 $\mu$ W                             |
| Frequency error                                     | < +1.5 kHz                            | < +1.5 kHz                                 |
| Adjacent channel power                              | < -70dB                               | < -70dBc                                   |

| Charger:        | Emergency mode<br>(emergency battery) | Regular mode<br>(rechargeable battery) |
|-----------------|---------------------------------------|--|
| Power source    | Not applicable                        | 12-24 VDC                              |
| Wall adapter    | Not applicable                        | 115-240 VAC                            |
| Mounting option | Not applicable                        | Table or wall mount                    |

|  |                                       |
|--|---------------------------------------|
|  <p><b>NOTE</b></p> | The nominal viewing distance is 0.8m. |
|--|---------------------------------------|

## 9.2 Option specification

### 9.2.1 NBB-748 Rechargeable Battery

|              |                        |
|--------------|------------------------|
| Size         | 61x86.7x19.3mm (W×H×D) |
| Mass         | Approx. 0.10kg         |
| Capacity     | 7.4V / 1500mAh         |
| Battery type | Lithium Polymer        |

### 9.2.2 NBB-789 Emergency Battery

|              |                        |
|--------------|------------------------|
| Size         | 61x86.7x19.3mm (W×H×D) |
| Mass         | Approx. 0.10kg         |
| Capacity     | 6.0V / 3000mAh         |
| Battery type | Lithium/Iron Disulfide |
| Expiry Date  | 5 years                |

### 9.2.3 NJD101037 Battery Charger

|               |                         |
|---------------|-------------------------|
| Size          | 92x74.5x114.2mm (W×H×D) |
| Mass          | Approx. 0.16kg          |
| Charging time | Approx 3 hours (type)   |

### 9.2.4 NJD101038 Power supply

|                       |                          |
|-----------------------|--------------------------|
| Size                  | 43.5x60.0x40.2mm (W×H×D) |
| Cable length          | 1250mm (type)            |
| Mass                  | Approx. 0.14kg           |
| Input Voltage Range   | 100V-240V / 47-63Hz      |
| Setting Voltage Range | 18VDC (type)             |
| Output Current        | 0.72 - 0.94A             |

## 9.2.5 7ZXJD0185 Peripheral set

### Wrist Strap

|           |                          |
|-----------|--------------------------|
| Size      | 8.0x215.0x45.0mm (W×H×D) |
| Mass      | Approx. 0.01kg           |
| Weak-link | Approx. 20kgf            |

## 9.2.6 NZB-191 Multi battery charger

|                     |   |
|---------------------|---|
| Size                | 400x97.6x140mm (W×H×D)                            |
| Cable length        | 1750mm (reference)                                |
| Mass                | Approx. 2.5kg (With 3 battery Chargers NJD101037) |
| Input Voltage Range | 100V-240V / 47-63Hz                               |

## 9.2.7 NJD19601 Headset push to talk module

|              |                          |
|--------------|--------------------------|
| Size         | 52.0x85.0x34.0mm (W×H×D) |
| Cable length | 530mm (type)             |
| Mass         | Approx. 0.14kg           |

## 9.2.8 7UMJD0021 Speaker Microphone

|                |                          |
|----------------|--------------------------|
| Size           | 67.1x81.3x27.2mm (W×H×D) |
| Cable length   | 470mm (type)             |
| Mass           | Approx. 0.22kg           |
| Speaker output | 0.5W (8Ω)                |



# 10 Installation

Since the JHS-207 can be supplied as a GMDSS or a Maritime VHF radio and each radio uses a different battery, ensure you install the batteries appropriately.

Following the applicable installation process according to the battery you will use; either the emergency battery or the rechargeable battery.

## **Important**

The Emergency battery should only be installed on the GMDSS radio in the event of an emergency.

## 10.1 Upon receipt of the radio

Upon receipt of the radio, do the following:

1. Connect the antenna.

## **Important**

When assembling the antenna to the radio, ensure you hold it at the base while turning it clockwise. When the antenna starts to resist turning, turn it another 90 degrees.

Holding the antenna anywhere but at the base during assembly will damage it.

## 10.2 In an emergency situation



### **Important**

The emergency seal sticker must not be removed from the battery unless an emergency situation occurs.

To install the emergency battery on the JHS-207, do the following:

2. Pull back and remove the emergency seal sticker on the battery.



|  |  |
|--|--|
|  <p><b>NOTE</b></p> | <p>Rip the sticker off at the perforated edge.</p>  |
|--|--|

3. Using the fixing track, mount the emergency battery onto the back of the radio.



**NOTE**

Do not force the battery.

Ensure you enter the bottom edge of the battery into the bottom edge of the radio.

4. Squeeze in the black finger grips on either side of the battery to lock the battery into place.



## 10.3 Replacing the emergency battery

If the emergency battery has expired or the battery has been used, it must be replaced with a new one. The emergency seal sticker must not be removed as only a sealed battery can be used in the case of an emergency. The battery and radio should always be stored together.

## 10.4 Installing the rechargeable battery

To install the rechargeable battery on the JHS-207 (Maritime VHF radio), do the following:

- 10.4.1. Using the fixing track, mount the rechargeable battery onto the back of the radio.



- 10.4.2. Squeeze in the black finger grips on either side of the battery to lock the battery into place.
- 10.4.3. Insert the wall adapter into the power input located on the underside of the charger.
- 10.4.4. Plug in the wall adapter.
- 10.4.5. Insert the radio into the Battery charger.



Do not force the radio into position in the charging bay.

10.4.6. Ensure that the radio is sitting properly in the Battery charger.



## 10.5 Changing the rechargeable battery

To change the rechargeable battery, do the following:

- 10.5.1. Press the ON/OFF button to turn off the radio.
- 10.5.2. Press both battery release clips at the same time, to release the battery.
- 10.5.3. Gently pull the top of the battery backwards and away from the radio.

10.5.4. Put the lower end of the new battery into the fixing track at the bottom of the radio.

10.5.5. Make sure both battery clips are fully engaged.



## **CAUTION**



Changing the battery must be done in a dry environment or under shelter as the radio is only waterproof when the battery, antenna and jack cover are correctly assembled

# 11 Operation instructions (GMDSS radio)

## 11.1 Emergency mode

When the emergency battery is connected, the radio starts in the emergency mode. Only basic functionality is available to the user in this mode. This battery is for use in a distress situation.

### **CAUTION**



When using an accessory, the radio will no longer be waterproof. The antenna and jack cover must be correctly assembled on the radio in order for it to be completely waterproof. Accessories should not be used when using the JHS-207 in the emergency mode.

#### Function:

Turning on a radio using an emergency battery. The circle in the top right corner appears when the radio is in the emergency mode.

#### Display screen:



11.1.1. Press and hold the power button for approximately 3 seconds to turn the radio on.

|  |   |
|--|---|
|  <p><b>NOTE</b></p> | <p>The radio loads the following settings:</p> <ul style="list-style-type: none"><li>• Channel 16</li><li>• Max power level (2W)</li><li>• High volume</li></ul> <p>Low squelch</p> |
|--|---|

## 11.2 Channel selection

Function:

Channel selection

11.2.1. Press or press and hold the up/down arrow buttons to change the channel.

|  |   |
|--|---|
|  <p><b>NOTE</b></p> | <p>When an emergency battery is connected, only GMDSS channels are available.</p> |
|--|---|

### **Important**

For information regarding available and active VHF marine radio channels and frequencies, please refer to ITU standards, with reference to the current World Radio Conference (WRC) agreement.

For an overview, refer to the Navigation Center website ([www.navcen.uscg.gov](http://www.navcen.uscg.gov), under Maritime Information, Maritime Telecommunications)



## 11.3 Channel 16 button

Function:  
Channel 16

Display screen:



11.3.1. Press the 16 button to jump directly to channel 16.

|   |   |
|---|---|
|  <p><b>NOTE</b></p> | The transmit power will always be set to Hi power when using the channel 16 button. |
|---|---|

## 11.4 Volume adjustment

Function:  
Volume adjustment

Display screen:



11.4.1. Turn the volume control to adjust the volume.

|  |  |
|--|--|
|  <p><b>NOTE</b></p> | The volume symbol in the display indicates the volume level.<br><br>Ensure that you do not press down the volume control while adjusting the volume. |
|--|--|

# 11.5 Squelch adjustment

Function:  
Squelch adjustment

Display screen:



The squelch bar appears on the screen display indicating the current active sensitivity level. When adjusted fully to the left, the squelch is completely open. Adjusting to the right lowers the receiver sensitivity.



The signal strength of the current channel appears on the bar below the squelch bar. If the received signal is strong enough, the squelch opens and voice is received. This is indicated by the Rx symbol.

When the squelch control is pressed twice, it opens the squelch immediately. Press twice again to recall the previous squelch setting.

- 11.5.1. Press and turn the squelch control anti-clockwise to increase receiver sensitivity.

|  |   |
|--|---|
|  <p><b>NOTE</b></p> | <p>When the receiver signal is too distorted (by radio noise) to be readable, the loudspeaker or speaker mic is automatically muted. This is indicated by the Noise Cancel (NC) symbol that appears in the display.</p>  |
|--|---|

## 11.6 Key lock and unlock

Function:

Key lock/unlock

Display screen:

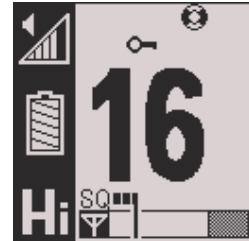

11.6.1. Press and hold the HI/LO button for 2 seconds to lock or unlock the buttons on the front.

|   |  |
|---|--|
|  <p><b>NOTE</b></p> | <p>A key symbol appears when the radio is locked.</p> <p>PTT, Channel 16, volume and squelch are still available when the radio is locked.</p> |
|---|--|

## 11.7 Watch

When the radio is in the emergency mode, it can only check for signals or watch in one way:

11.7.1. Dualwatch

DW listens to the active channel and channel 16.

## **Important**

The radio will continue to watch channel 16 while receiving on other channels.



**NOTE**

When you press PTT the radio will transmit on the active channel.

In addition, the watch function will be deactivated.

### 11.7.1 Dual watch

Function:

Dual watch (DW)

The DW function allows the user to monitor channel 16 and the active channel alternately.

Display screen:

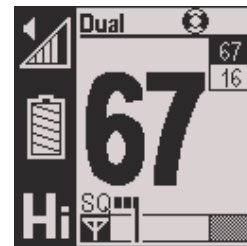

To activate or deactivate DW, do the following:

1. Press Scan to activate dual watch.
2. Press the up/down buttons to watch a second channel.
3. Press Scan a second time to deactivate dual watch.

## 11.8 Menus

Press the up/down arrow buttons at the same time to enter or exit the menu system.  
Use the up/down arrow buttons to navigate and select using Scan/Enter.

Menus:

Exit:

Use this menu option to exit the menu system.

Display screen:



Settings:

Use this menu option to adjust the following settings:

- Key sound
- Key volume
- Backlight time
- Backlight level
- Contrast
- Key lock time

Display screen:

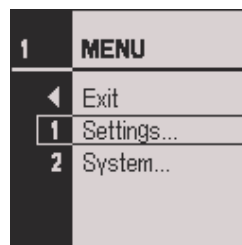

Menu number:

1

**Key sound:**

Use this menu option to choose an audio tone. You can choose between four different tones.

Using the up/down arrow keys, select from 1-4.

**Display screen:**

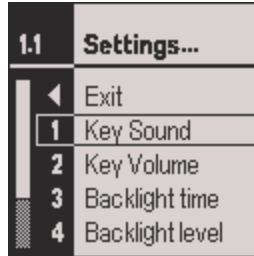

**Menu number:**

1.1

**Key volume:**

Use this menu option to set the volume of the key sound.

(Off=0, low to high=1-6)

**Display screen:**

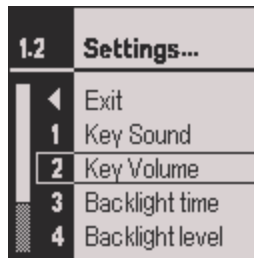

**Menu number:**

1.2

**Backlight time:**

Use this menu option to set the time while the backlight is on (1-10 seconds). The backlight will go off automatically.

**Display screen:**

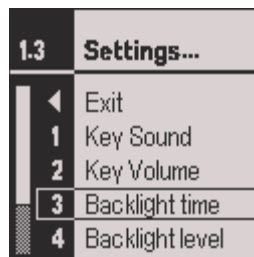

**Menu number:**

1.3

**Backlight level:**

Use this menu option to set the display backlight level.

(Off=0, low=1 or high=2)

**Display screen:**

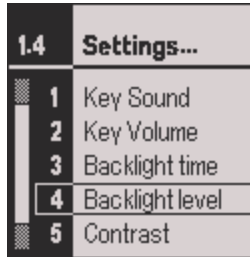

| 1.4 | Settings...     |
|-----|-----------------|
| 1   | Key Sound       |
| 2   | Key Volume      |
| 3   | Backlight time  |
| 4   | Backlight level |
| 5   | Contrast        |

**Menu number:**

1.4

**Contrast:**

Use this menu option to set the display contrast level

(Low=1, medium= 2 or high=3)

**Display screen:**

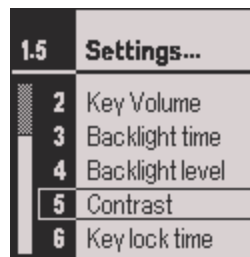

| 1.5 | Settings...     |
|-----|-----------------|
| 2   | Key Volume      |
| 3   | Backlight time  |
| 4   | Backlight level |
| 5   | Contrast        |
| 6   | Key lock time   |

**Menu number:**

1.5

**Key lock time:**

Use this menu option to set the time before the key lock automatically turns on.

This can be adjusted from 5-60 (in increments of five seconds).

**Display screen:**

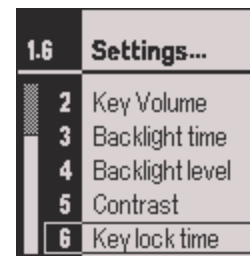

| 1.6 | Settings...     |
|-----|-----------------|
| 2   | Key Volume      |
| 3   | Backlight time  |
| 4   | Backlight level |
| 5   | Contrast        |
| 6   | Key lock time   |

**Menu number:**

1.6

(0=keylock time turned off)

**System:**

Use this menu option to access the following information:

- Serial Number
- SW version
- HW version

**Display screen:**

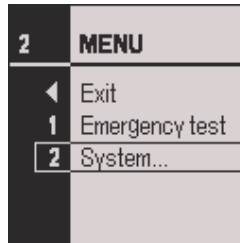

**Menu number:**

2

**Serial Number:**

Use this menu option to find the serial number of the radio.

**Display screen:**

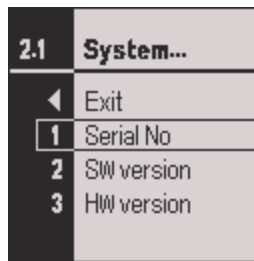

**Menu number:**

2.1

**SW Version:**

Use this menu option to find the software version of this radio.

**Display screen:**

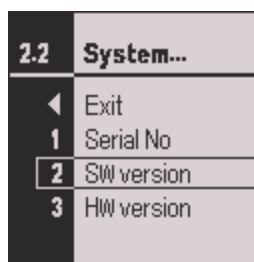

**Menu number:**

2.2



HW Version:

Use this menu option to find the hardware version of this radio.

Display screen:  
Menu number:

Menu number:  
2.3

|            |                  |
|------------|------------------|
| <b>2.3</b> | <b>System...</b> |
| ◀          | Exit             |
| 1          | Serial No        |
| 2          | SW version       |
| 3          | HW version       |



# 12 Operation instructions (Maritime VHF radio)

## 12.1 Regular radio mode

When the rechargeable battery is connected additional functionality is available. All VHF channels are available with triple watch and custom channel scan. In addition, three transmit power levels are also available.

Function

Turning on a radio using a rechargeable battery.

Display screen:

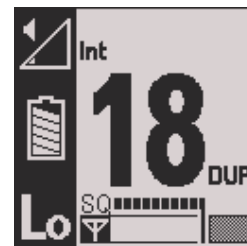

- 12.1.1. Press and hold the power button for approximately 3 seconds to turn the radio on.

|  |   |
|--|---|
|  <p><b>NOTE</b></p> | The radio loads settings based on previous usage. |
|--|---|

## 12.2 Channel selection

Function:

Channel selection

12.2.1. Press or press and hold the up/down arrow buttons to change the channel.

|  |   |
|--|---|
|  <p><b>NOTE</b></p> | <p>When a rechargeable battery is connected, all VHF maritime channels are available.</p> |
|--|---|

### **Important**

For information regarding available and active VHF marine radio channels and frequencies, please refer to ITU standards, with reference to the current World Radio Conference (WRC) agreement.

For an overview, refer to the Navigation Center website ([www.navcen.uscg.gov](http://www.navcen.uscg.gov), under Maritime Information, Maritime Telecommunications)

## 12.3 Channel 16 button

Function:

Channel 16

Display screen:



1. Press the 16 button to jump directly to channel 16.

|  |  |
|--|--|
|  <p><b>NOTE</b></p> | The transmit power will always be set to Hi power when using the channel 16 button, even if you switch from another channel. |
|--|--|

## 12.4 Call channel

Function:  
Call channel

Display screen:

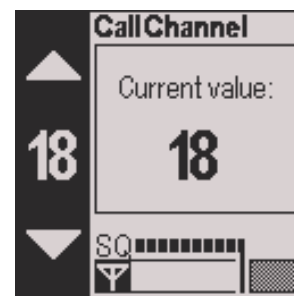

To program a call channel, do the following:

- 12.4.1. Press and hold the channel 16 button for 2 seconds to enter the call channel.

|  |  |
|--|--|
|  <p><b>NOTE</b></p> | The radio will go to the programmed call channel. The default call channel is Channel 9. |
|--|--|

- 12.4.2. Press and hold the channel 16 button again to change the call channel.

12.4.3. Press up/down arrow buttons to select the desired channel.

12.4.4. Press and hold Mem in for 2 seconds to save the channel.

|  |  |
|--|--|
|  <p><b>NOTE</b></p> | <p>The current value updates within approximately 2 seconds.</p> <p>The desired call channel is marked with a C that appears on the radio display.</p> |
|--|--|

12.4.5. Press the channel 16 button to close the menu.

|   |   |
|---|---|
|  <p><b>NOTE</b></p> | <p>To recall the desired channel, press the channel 16 button for 2 seconds.</p> <p>You can also press Scan to exit the programming mode.</p> |
|---|---|

## 12.5 Custom channels

In the regular radio mode the JHS-207 is capable of storing up to 20 custom channels, which must be programmed by a radio supplier.

To view the pre-programmed custom channels, select the Custom channel menu (Refer to the Menus section under the operation instructions for the maritime VHF radio).

All custom channels are identified by a letter followed by a number. The letters can be any of the following:

| Channel letter: | Channel ID: | Channel type:                        |
|-----------------|-------------|--------------------------------------|
| F               | "F"         | Fishing channel                      |
| L               | "L"         | Leisure channel                      |
| M               | "M"         | Yacht and leisure channels (UK only) |
| P               | "P"         | Private channel                      |
| W               | "W"         | Weather channel                      |

## 12.6 Volume adjustment

Function:  
Volume adjustment

Display screen:



12.6.1. Turn the volume control to adjust the volume.

|  |  |
|--|--|
|  <p><b>NOTE</b></p> | <p>The volume symbol in the display indicates the volume level.<br/>Ensure that you do not press down the volume control while adjusting the volume.</p> |
|--|--|

## 12.7 Squelch adjustment

Function:

### Squelch adjustment

The squelch bar appears on the screen display indicating the current active sensitivity level. When adjusted fully to the left, the squelch is completely open. Adjusting to the right lowers the receiver sensitivity.

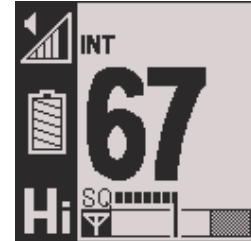

Display screen:



The signal strength of the current channel appears on the bar below the squelch bar. If the received signal is strong enough, the squelch opens and voice is received. This is indicated by the Rx symbol.

When the squelch control is pressed twice, it opens the squelch immediately. Press twice again to recall the previous squelch setting.

12.7.1. Press and turn the squelch control anti-clockwise to increase receiver sensitivity.

|  |   |
|--|---|
|  <p><b>NOTE</b></p> | <p>When the receiver signal is too distorted (by radio noise) to be readable, the loudspeaker or speaker mic is automatically muted. This is indicated by the Noise Cancel (NC) symbol that appears in the display.</p>  |
|--|---|



## 12.8 Key lock and unlock

Function:

Key lock/unlock

Display screen:



- 12.8.1. Press and hold the HI/LO button for 2 seconds to lock or unlock buttons on the front.

|   |  |
|---|--|
|  <p><b>NOTE</b></p> | <p>A key symbol appears when the radio is locked.</p> <p>PTT, volume and squelch are still available when the radio is locked.</p> |
|---|--|

## 12.9 Watch

When the radio is in the regular VHF mode, it can check for signals or watch in three ways:

- 12.9.1. Dual watch
- 12.9.2. Triple watch
- 12.9.3. Scan

## **Important**

The radio will continue to watch channel 16 while receiving on other channels.



**NOTE**

When you press PTT the radio will transmit on the active channel.

In addition, the watch function you are currently in (DW, TW or Scan) will be deactivated.

### 12.9.1 Dual watch

Function:

Dual watch (DW)

The DW function allows the user to monitor channel 16 and the active channel alternately.

The channel search indicator is visible on the display, however, the channels do not appear in real time.

To select DW setup, do the following:

1. Press the up/down arrow buttons at the same time to enter the menu.
2. Using the arrow buttons, select Settings.
3. Using the arrow buttons, select DW/TW.

Display screen:

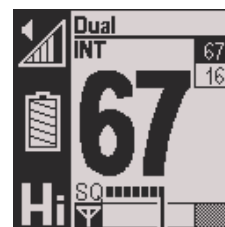

4. Using the arrow buttons, select DW.
5. If the radio is not already set to DW, then select SAVE.

To activate or deactivate DW, do the following:

1. Press Scan to activate dual watch.
2. Press the up/down buttons to watch a second channel.
3. Press Scan a second time to deactivate dual watch.

## 12.9.2 Triple watch

Function:

Triple watch

The TW function allows the user to monitor channel 16, the chosen call channel and the active channel alternately.

The channel search indicator is visible on the display, however, the channels do not appear in real time.

Display:

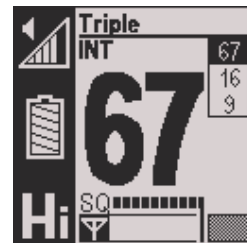

To select TW setup, do the following:

1. Press the up/down arrow buttons at the same time to enter the menu.
2. Using the arrow buttons, select Settings.
3. Using the arrow buttons, select DW/TW.
4. Using the arrow buttons, select TW.

5. If the radio is not already set to TW, then select SAVE.

To activate or deactivate TW, do the following:

1. Press Scan to activate triple watch.
2. Press the up/down buttons to watch a third channel.
3. Press Scan a second time to deactivated triple watch.

### 12.9.3 Scan

Function:

Scan

The scan function allows the radio can scan up to 12 memory channels (Channel 16 and the active channel are automatically included).

Display screen:

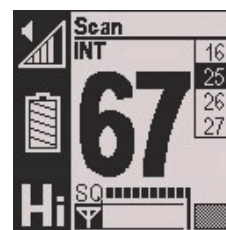

#### **Important**

The radio is supplied without any pre-programmed channels, therefore, until a channel is added into the memory you will not have a channel available to scan. In this case, when you press Scan you will automatically go directly to the Scan Prog screen.

All stored channels can be browsed by pressing the Mem button. Stored channels are displayed with an M.



To activate or deactivate Scan, do the following:

1. Press and hold Scan for 2 seconds to activate and short click to deactivate.

|  |   |
|--|---|
|  <p><b>NOTE</b></p> | The scan indicator is visible on the display, however, the channels do not appear in real time. |
|--|---|

### 12.9.3.1 Scan Prog

Function:  
Scan Prog

Display screen:

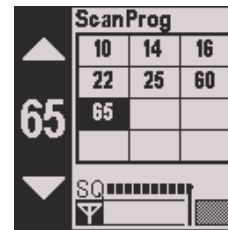

You can store and delete memory channels for scanning in two ways, do one of the following:

- Quick method, to be done when scan is not active.
- Visual method, to be done when scan is active.

Quick method:

1. Navigate to the channel you want to store or delete from the memory.
2. Press and hold Mem for 2 seconds to store or delete the selected channel from memory.

Visual method:

1. Press and hold the Scan button for 2 seconds to activate Scan.
2. Press and hold the Scan button for 2 seconds again to enter the scan program screen.
3. Use the up/down arrow buttons to select the desired channel.
4. Press and hold the Mem button in for 2 seconds to add or remove the current channel.
5. Press Scan to exit Scan Prog.

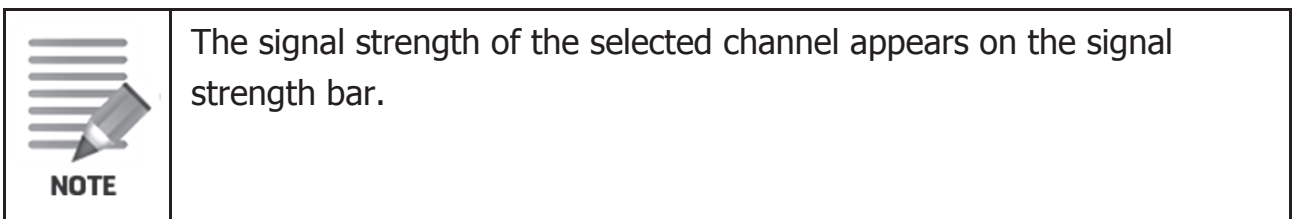

## 12.10 Menus

Press the up/down arrow buttons at the same time to enter or exit the menu system. Use the up/down arrow buttons to navigate and select using Scan/Enter.

Menus:

Exit:

Use this menu option to exit the menu system.

Display screen:

| MENU |                |
|------|----------------|
| ◀    | Exit           |
| 1    | Emergency test |
| 2    | Settings...    |
| 3    | Custom Ch...   |
| 4    | System...      |

Emergency test:

Use this menu option for drills/testing or when you want the radio to behave like a GMDSS radio

Display screen:

| 1 | MENU           |
|---|----------------|
| ◀ | Exit           |
| 1 | Emergency test |
| 2 | Settings...    |
| 3 | Custom Ch...   |
| 4 | System...      |

Menu number:

1

Settings:

Use this menu option to adjust the following settings:

- Key sound
- Key volume
- DW/TW
- Backlight time
- Backlight level

Display screen:

| 2 | MENU           |
|---|----------------|
| ◀ | Exit           |
| 1 | Emergency test |
| 2 | Settings...    |
| 3 | Custom Ch...   |
| 4 | System...      |

Menu number:

2

- Contrast
- Key lock time
- Channel set
- Speaker/Mic

**Key sound:**

Use this menu option to choose an audio tone. You can choose between four different tones.

Using the up/down arrow keys, select from 1-4.

**Display screen:**

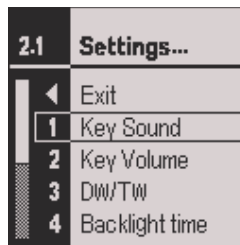

**Menu number:**  
2.1

**Key volume:**

Use this menu option to set the volume of the key sound.

(Off=0, low to high= 1-6)

**Display screen:**

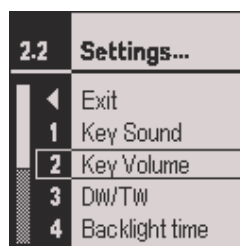

**Menu number:** 2.2



### DW/TW:

Use this menu option to choose if you want to use dual watch or triple watch.

Use the up/down arrow keys, select either DW or TW.

### Display screen:

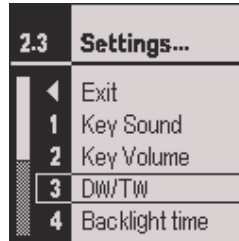

### Menu number:

2.3

### Backlight time:

Use this menu option to set the time while the backlight is on (1-10 seconds). The backlight will go off automatically.

### Display screen:

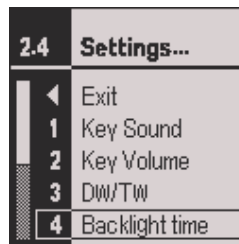

### Menu number:

2.4

### Backlight level:

Use this menu option to set the display backlight level.

(Off=0, low=1 or high=2)

### Display screen:

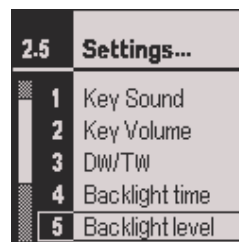

### Menu number:

2.5

### Contrast:

Use this menu option to set the display contrast level

(Low=1, medium= 2 or high=3)

### Display screen:

| 2.6 | Settings...     |
|-----|-----------------|
| 2   | Key Volume      |
| 3   | DW/TW           |
| 4   | Backlight time  |
| 5   | Backlight level |
| 6   | Contrast        |

### Menu number:

2.6

### Key lock time:

Use this menu option to set the time before the key lock automatically turns on.

This can be adjusted from 5-60 (in increments of five seconds).

(0=keylock time turned off)

### Display screen:

| 2.7 | Settings...     |
|-----|-----------------|
| 3   | DW/TW           |
| 4   | Backlight time  |
| 5   | Backlight level |
| 6   | Contrast        |
| 7   | Key lock time   |

### Menu number:

2.7

### Channelset:

Use this menu option to change the channel set according to the region where the radio will be in use.

### Display screen:

| 2.8 | Settings...     |
|-----|-----------------|
| 4   | Backlight time  |
| 5   | Backlight level |
| 6   | Contrast        |
| 7   | Key lock time   |
| 8   | Channel set     |

### Menu number:

2.8

**Speaker/Mic:**

Use this menu option when connecting an external speaker/mic. This option allows you to select where the sound comes from, either the internal loudspeaker or the external speaker mic.

**Display screen:**

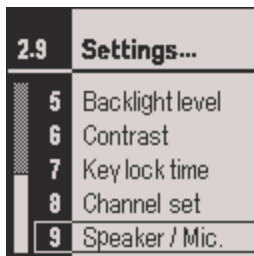

|            |                    |
|------------|--------------------|
| <b>2.9</b> | <b>Settings...</b> |
| 5          | Backlight level    |
| 6          | Contrast           |
| 7          | Key lock time      |
| 8          | Channel set        |
| 9          | Speaker / Mic.     |

**Menu number:**

2.9

You need to restart the radio after you configure it in order for the changes to take effect.

**Mic. Only:** The sound comes from the internal loudspeaker of the radio when the microphone in the speaker/mic is in use.

**Loudsp. +mic:** The sound comes from the external speaker mic.

**Custom channel:**

Use this menu option to view the pre-programmed custom channel.

To view transmitting and receiving frequencies press enter on the selected custom channel.

**Display screen:**

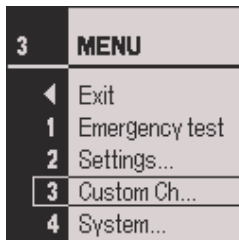

|          |                |
|----------|----------------|
| <b>3</b> | <b>MENU</b>    |
| ◀        | Exit           |
| 1        | Emergency test |
| 2        | Settings...    |
| 3        | Custom Ch...   |
| 4        | System...      |

**Menu number:**

3

**System:**

Use this menu to access the following additional menu options:

- Serial Number
- SW version
- HW version
- Factory reset

**Display screen:**

|          |                |
|----------|----------------|
| <b>4</b> | <b>MENU</b>    |
| ◀        | Exit           |
| <b>1</b> | Emergency test |
| <b>2</b> | Settings...    |
| <b>3</b> | Custom Ch...   |
| <b>4</b> | System...      |

**Menu number:**

4

**Serial Number:**

Use this menu option to find the serial number of the radio.

**Display screen:**

|            |                  |
|------------|------------------|
| <b>4.1</b> | <b>System...</b> |
| ◀          | Exit             |
| <b>1</b>   | Serial No        |
| <b>2</b>   | SW version       |
| <b>3</b>   | HW version       |
| <b>4</b>   | Factory reset    |

**Menu number:**

4.1

**SW Version:**

Use this menu option to find the software version of this radio.

**Display screen:**

|            |                  |
|------------|------------------|
| <b>4.2</b> | <b>System...</b> |
| ◀          | Exit             |
| <b>1</b>   | Serial No        |
| <b>2</b>   | SW version       |
| <b>3</b>   | HW version       |
| <b>4</b>   | Factory reset    |

**Menu number:**

4.2

HW Version:  
Use this menu option to find the hardware version of this radio.

Display screen:

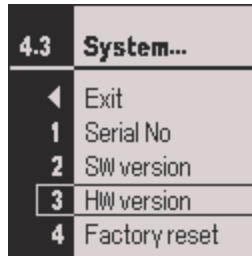

Menu number:  
4.3

Factory reset:  
Use this menu option to reset all user settings.

Display screen:

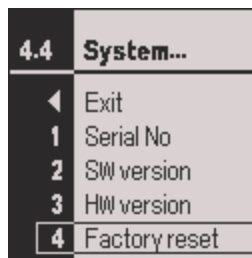

Menu number:  
4.4

## 12.11 External accessories

Function:  
External accessories

Display screen:

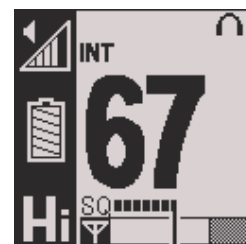

The headphone symbol appears in the display screen when you connect an external accessory, such as a headphone, microphone or external PTT. It is also possible to choose the internal loudspeaker when using an external speaker mic.

Connector type: 3,5mm 4 pole jack.



## **CAUTION**





When using an accessory, the radio will no longer be waterproof.

The antenna and jack cover must be correctly assembled on the radio in order for it to be completely waterproof.

Accessories should not be used when using the JHS-207 in the emergency mode.

# 13 Maintenance

The following maintenance should be completed.

|  |   |
|--|---|
|  <b>CAUTION</b> |   |
|                 | <p>The JHS-207 is a sealed waterproof radio, and does not contain any user serviceable parts inside.</p> <p>This radio must never be opened by anyone other than an authorized JRC agent. Unauthorized disassembly will void your warranty.</p> |

If the radio is immersed in seawater, rinse it with fresh water immediately, otherwise, wash away dirt and oil from the radio with warm water (no higher than 45 degrees celsius) and mild dish soap.

Finish by rinsing with fresh water and drying.

|  |   |
|--|---|
| <br><b>NOTE</b> | <p>Only wash the exterior of the radio.</p> |
|--|---|

## 13.1 Regular inspection

The lifetime of any equipment depends on how well you take care of it. The JHS-207 is constructed to endure in a rough maritime environment. Regular inspection is important to detect error symptoms and prevent potentially serious problems.

To inspect, do the following:

- 13.1.1. Inspect the battery connection pins, the gasket and the lock/release device.
- 13.1.2. Inspect the housing for defects regularly. This is important as defects can affect water sealing.



## **CAUTION**



Ensure that the antenna and jack cover are assembled correctly, if not the radio is not waterproof.

## 13.2 Regular testing

It is important to perform regular testing of equipment to ensure proper operation. This also ensures the radio is in good working order and therefore ready for use in a potential emergency situation.

### **Important**

Ensure you have a rechargeable battery available for use during testing to avoid using a sealed lithium battery.

Testing should occur according to the requirements indicated in the on board radio log.

To test, do the following:

- 13.2.1. Use the rechargeable battery.
- 13.2.2. Turn the radio on and choose an appropriate channel other than 16.



- 13.2.3. Verify sending a transmission to another radio.
- 13.2.4. Verify receiving a transmission from another radio.
- 13.2.5. Turn off the radio.
- 13.2.6. Verify that the emergency battery is still valid.

|  |   |
|--|---|
|  <p><b>NOTE</b></p> | The expiry date is located on the top of the battery. |
|--|---|

- 13.2.7. Verify that the emergency battery is still sealed.

|  |  |
|--|--|
|  <p><b>NOTE</b></p> | If the seal on the emergency battery is broken, replace the battery immediately. |
|--|--|



# 14 Channels and frequencies

## **Important**

Regulations for the use of VHF radios varies from country to country. Check the national radio requirements for VHF radio operators and ensure this radio conforms to all the local regulations, prior to use.

The channel frequencies listed in this manual reflect only as they are available and displayed on the radio.



Some previously available channels may not be available for use in your region.

For example, Channel 23, 84 and 86 are no longer used for either Maritime Safety Information (MSI) or Radio Medical Advice.

## **Important**

Due to the introduction of new services on frequencies that were previously used by maritime voice communications, you must refer to your local regulations to find out which channels you can use.

These maritime frequency channel changes commenced 1 January 2017. This will be a gradual and ongoing process, with different regulations around the world.

The new four digit channel number format is not available on this radio.

Simplex use of the ship station (transmit side) of what was the international duplex channel is marked as "A" on the radio. The new channel format adds the number 10 in front of the channel (for example, channel 5A will be the same as channel 1005).

Simplex use of the coast station (transmit side) of what the international duplex channel is marked as "B" on the radio. The new channel format adds the number 20 in front of the channel (for example, channel 5B will be the same as 2005).

## 14.1 GMDSS

| Channel Number | TX/RX (MHz) | Channel number | TX/RX (MHz) | Channel number | TX/RX (MHz) |
|----------------|-------------|----------------|-------------|----------------|-------------|
| 6              | 156.300     | 14             | 156.700     | 71             | 156.575     |
| 8              | 156.400     | 15             | 156.750*    | 72             | 156.625     |
| 9              | 156.450     | 16             | 156.800     | 73             | 156.675     |
| 10             | 156.500*    | 17             | 156.850*    | 74             | 156.725     |
| 11             | 156.550*    | 67             | 156.375     | 77             | 156.875     |
| 12             | 156.600     | 68             | 156.425     | 87             | 157.375     |
| 13             | 156.650     | 69             | 156.475     | 88             | 157.425     |

\* Low power mode with TX transmit power limited to 1W

## 14.2 International (ITU)

| Channel Number | TX (MHz) | RX (MHz) | Channel Number | TX (MHz) | RX (MHz) | Channel number | TX (MHz) | RX (MHz) |
|----------------|----------|----------|----------------|----------|----------|----------------|----------|----------|
| 1              | 156.050  | 160.650  | 19             | 156.950  | 161.550  | 68             | 156.425  | 156.425  |
| 2              | 156.100  | 160.700  | 20             | 157.000  | 161.600  | 69             | 156.475  | 156.475  |
| 3              | 156.150  | 160.750  | 21             | 157.050  | 161.650  | 71             | 156.575  | 156.575  |
| 4              | 156.200  | 160.800  | 22             | 157.100  | 161.700  | 72             | 156.625  | 156.625  |
| 5              | 156.250  | 160.850  | 23             | 157.150  | 161.750  | 73             | 156.675  | 156.675  |
| 6              | 156.300  | 156.300  | 24             | 157.200  | 161.800  | 74             | 156.725  | 156.725  |
| 7              | 156.350  | 160.950  | 25             | 157.250  | 161.850  | 77             | 156.875  | 156.875  |
| 8              | 156.400  | 156.400  | 26             | 157.300  | 161.900  | 78             | 156.925  | 161.525  |
| 9              | 156.450  | 156.450  | 27             | 157.350  | 161.950  | 79             | 156.975  | 161.575  |
| 10             | 156.500* | 156.500  | 28             | 157.400  | 162.000  | 80             | 157.025  | 161.625  |
| 11             | 156.550* | 156.550  | 60             | 156.025  | 160.625  | 81             | 157.075  | 161.675  |
| 12             | 156.600  | 156.600  | 61             | 156.075  | 160.675  | 82             | 157.125  | 161.675  |
| 13             | 156.650  | 156.650  | 62             | 156.125  | 160.725  | 83             | 157.175  | 161.775  |
| 14             | 156.700  | 156.700  | 63             | 156.175  | 160.775  | 84             | 157.225  | 161.825  |
| 15             | 156.750* | 156.750  | 64             | 156.225  | 160.825  | 85             | 157.275  | 161.875  |
| 16             | 156.800  | 156.800  | 65             | 156.275  | 160.975  | 86             | 157.325  | 161.925  |
| 17             | 156.850* | 156.850  | 66             | 156.325  | 160.925  | 87             | 157.375  | 157.375  |
| 18             | 156.900  | 161.500  | 67             | 156.375  | 156.375  | 88             | 157.425  | 157.425  |

\* Low power mode with TX transmit power limited to 1W

## 14.3 USA

| Channel Number | TX (MHz) | RX (MHz) | Channel Number | TX (MHz) | RX (MHz) | Channel number | TX (MHz) | RX (MHz) |
|----------------|----------|----------|----------------|----------|----------|----------------|----------|----------|
| 1A             | 156.050  | 156.050  | 19A            | 156.950  | 156.950  | 71             | 156.575  | 156.575  |
| 5A             | 156.250  | 156.250  | 20             | 157.000  | 161.600  | 72             | 156.625  | 156.625  |
| 6              | 156.300  | 156.300  | 20A            | 157.000  | 157.000  | 73             | 156.675  | 156.675  |
| 7A             | 156.350  | 156.350  | 22A            | **       | 157.100  | 74             | 156.725  | 156.725  |
| 8              | 156.400  | 156.400  | 24             | 157.200  | 161.800  | 75             | 156.775* | 156.775  |
| 9              | 156.450  | 156.450  | 25             | 157.250  | 161.850  | 76             | 156.825* | 156.825  |
| 10             | 156.500* | 156.500  | 26             | 157.300  | 161.900  | 77             | 156.875  | 156.875  |
| 11             | 156.550* | 156.550  | 27             | 157.350  | 161.950  | 78A            | 156.925  | 156.925  |
| 12             | 156.600  | 156.600  | 28             | 157.400  | 162.000  | 79A            | 156.975  | 156.975  |
| 13             | 156.650  | 156.650  | 63A            | 156.175  | 156.175  | 80A            | 157.025  | 157.025  |
| 14             | 156.700  | 156.700  | 65A            | 156.275  | 156.275  | 84             | 157.225  | 161.825  |
| 15             | **       | 156.750  | 66A            | 156.325  | 156.325  | 85             | 157.275  | 161.875  |
| 16             | 156.800  | 156.800  | 67             | 156.375  | 156.375  | 86             | 157.325  | 161.925  |
| 17             | 156.850* | 156.850  | 68             | 156.425  | 156.425  | 87             | 157.375  | 157.375  |
| 18A            | 156.900  | 156.900  | 69             | 156.475  | 156.475  | 88             | 157.425  | 157.425  |

\* Low power mode with TX transmit power limited to 1W

\*\* RX only

## 14.4 Canada

| Channel Number | TX (MHz) | RX (MHz) | Channel Number | TX (MHz) | RX (MHz) | Channel number | TX (MHz) | RX (MHz) |
|----------------|----------|----------|----------------|----------|----------|----------------|----------|----------|
| 1              | 156.050  | 160.650  | 20             | 157.000* | 161.600  | 67             | 156.375  | 156.375  |
| 2              | 156.100  | 160.700  | 21B            | **       | 161.650  | 68             | 156.425  | 156.425  |
| 3              | 156.150  | 160.750  | 23             | 157.150  | 161.750  | 69             | 156.475  | 156.475  |
| 4A             | 156.200  | 156.200  | 23B            | **       | 161.750  | 71             | 156.575  | 156.575  |
| 5A             | 156.250  | 156.250  | 24             | 157.200  | 161.800  | 72             | 156.625  | 156.625  |
| 6              | 156.300  | 156.300  | 25             | 157.250  | 161.850  | 73             | 156.675  | 156.675  |
| 7A             | 156.350  | 156.350  | 25B            | **       | 161.850  | 74             | 156.725  | 156.725  |
| 8              | 156.400  | 156.400  | 26             | 157.300  | 161.900  | 75             | 156.775* | 156.775  |
| 9              | 156.450  | 156.450  | 27             | 157.350  | 161.950  | 76             | 156.825* | 156.825  |
| 10             | 156.500* | 156.500  | 28             | 157.400  | 162.000  | 77             | 156.875  | 156.875  |
| 11             | 156.550* | 156.550  | 28B            | **       | 162.000  | 78A            | 156.925  | 156.925  |
| 12             | 156.600  | 156.600  | 60             | 156.025  | 160.625  | 79A            | 156.975  | 156.975  |
| 13             | 156.650  | 156.650  | 61A            | 156.075  | 156.075  | 80A            | 157.025  | 157.025  |
| 14             | 156.700  | 156.700  | 62A            | 156.125  | 156.125  | 83B            | **       | 161.775  |
| 15             | 156.750* | 156.750  | 63A            | 156.175  | 156.175  | 84             | 157.225  | 161.825  |
| 16             | 156.800  | 156.800  | 64             | 156.225  | 160.825  | 85             | 157.275  | 161.875  |
| 17             | 156.850* | 156.850  | 64A            | 156.225  | 156.225  | 86             | 157.325  | 161.925  |
| 18A            | 156.900  | 156.900  | 65A            | 156.275  | 156.275  | 87             | 157.375  | 157.375  |
| 19A            | 156.950  | 156.950  | 66A            | 156.325  | 156.325  | 88             | 157.425  | 157.425  |

\*Low power mode with TX transmit power limited to 1W

\*\* RX only





# 15 AFTER-SALES SERVICE

## ★ Warranty

The warranty period is determined by JRC's warranty regulations, but is normally 1 year from the date of purchase. Additionally, the warranty except for the body text is submitted to contractual agreements.

## ★ Repair Part Inventory Period

Parts necessary for proper functioning of this equipment will be kept available for 10years after product discontinuation.

## ★ When Requesting Repairs

If the problem is due to a defect, immediately stop use of the system and contact the store at which you purchased the system, or one of our branches.

- During the warranty period , if a malfunction occurs with the equipment while in standard usage in accordance with this instruction manual, we or our agencies will repair the malfunction at no charge at the store where the equipment was purchased or another location specified by JRC. If the malfunction occurs due to improper usage, fault, or any external abnormal condition such as fire, pollution, abnormal voltage, natural disaster (ex. thunder storms, earthquake) etc., JRC will repair the equipment for a fee. Furthermore, regardless of the warranty period, orders of consumables will be charged.
- After the warranty expires , we will repair the malfunction for a fee, if repair is possible.
- Please inform us of the following :
  - ☆ Product name, model name, manufactured date, serial number
  - ☆ As much information as you can provide about the malfunction.  
(whether transmission is possible or not, etc.)
  - ☆ Your company or organization name, address, and phone number

## ★ Periodical Maintenance Recommendation

Depending on usage conditions, with extended use, the performance of this equipment may degrade over time, and externally installed parts such as the antenna may degrade due to vibration, so we recommend periodical maintenance in addition to the standard maintenance.

Please contact the store where you purchased the equipment, or one of our branches, to request periodical maintenance. Periodical maintenance requires a service charge.

If you have any questions regarding after-sales service, please contact the store where you purchased the equipment, or one of our branches.

Refer to the inside of the back cover for contact numbers and locations.

# 16 DISPOSAL

Observe all rules and regulations of the local authorities when disposing of this equipment.





アスベストは使用していません  
Not use the asbestos

*For further information, contact:*

**JRC** *Japan Radio Co., Ltd.*

*Since 1915*

URL Head office : <http://www.jrc.co.jp/eng/>

Marine Service Department

1-7-32 Tatsumi, Koto-ku, Tokyo 135-0053, Japan

e-mail : [tmsc@jrc.co.jp](mailto:tmsc@jrc.co.jp)

One-call : +81-50-3786-9201

ISO 9001, ISO 14001 Certified